

## OPW 1-2100 Series Thread-On Spill Containers

OPW Spill Containment Manholes are designed to prevent spilled product from entering the soil near the fill and vapor return riser connections on underground storage tanks during normal tank filling operation, or in the event of tank overflow. The spill containers catch spillage to help prevent soil contamination and groundwater pollution. OPW Thread-On Spill Containment Manholes are generally used on new tank or riser pipe installations.

### Materials

**Cover:** Cast aluminum or cast iron  
**Mounting Ring:** Cast iron E-coating  
**Bellows:** Polyethylene  
**Base:** Cast iron E-coating or Duratuff II  
**Clamps:** Stainless steel  
**Seals:** Nitrile



1-2115,  
15-Gallon

### Features

- ◆ **Easy Installation** – reduces job-site time and installation costs. OPW Thread-On Spill Containers screw directly onto 4" NPT riser. No external connections to make; adjust the final grade height and support the unit with backfill.
- ◆ **Integral Pull-to-Open Drain Valve** – allows high-speed drainage of excess product into the tank. Designed with a convenient self-cleaning seal and removable screen for easier component cleaning.
- ◆ **Capacity** – available in a true 5-gallon capacity as well as 15-gallon capacity.
- ◆ **Rain-Shedding Cover** – available in either cast aluminum or cast iron, this unique design incorporates a seal in the underside of the cover. The seal seats between two dams on the mounting ring to prevent surface water from entering the spill container.
- ◆ **Fuel Compatibility** – designed to accommodate the fuels of the future, including methanol, ethanol and fuels with MTBE additives.
- ◆ **Product Identification Tags** – available for both the cover and bucket to positively identify the product contained in the UST with standard API symbols. (See product I.D. tag specification page for more information: page 82.)
- ◆ **Heavy-Duty Mounting Ring** – the angled ramp design offers superior protection against snow plow and traffic damage, and provides for secure concrete anchoring.
- ◆ **Corrugated Bellows** – can be adjusted +/- 1 inch for desired grade level.
- ◆ **Duratuff® II or Cast Iron Base** – composite Duratuff® II material is lightweight, durable, and conductive. A rugged, optional, cast-iron base is also available.
- ◆ **Highway 20 Rated (H20)** – all OPW spill containers and manholes exceed the requirements of the Highway 20 rating.

### Listings and Certifications



Look for this label for authentic OPW EVR Approved products.

**DEVR Models – Fill Port with Drain Valve**

**Duratuff® II Base with Drain Valve Models**

Model #	Gal.	Liter	Cover	lbs.	kg
1-2100-DEVR	5	19	Aluminum	40	18
1C-2100-DEVR	5	19	Cast Iron	53	24
1-2115-DEVR	15	57	Aluminum	47	21
1C-2115-DEVR	15	57	Cast Iron	60	27

**Cast Iron Base with Drain Valve Models**

Model #	Gal.	Liter	Cover	lbs.	kg
1-2100C-DEVR	5	19	Aluminum	40	18
1C-2100C-DEVR	5	19	Cast Iron	53	24
1-2115C-DEVR	15	57	Aluminum	47	21
1C-2115C-DEVR	15	57	Cast Iron	60	27

**PEVR Models – Vapor Port with Plug**

**Duratuff® II Base with Plug Models**

Model #	Gal.	Liter	Cover	lbs.	kg
1-2100-PEVR	5	19	Aluminum	40	18
1C-2100-PEVR	5	19	Cast Iron	53	24

**Cast Iron Base with Plug Models**

Model #	Gal.	Liter	Cover	lbs.	kg
1-2100C-PEVR	5	19	Aluminum	40	18
1C-2100C-PEVR	5	19	Cast Iron	53	24



**4" Threaded Nipples for Mating Spill Bucket to Adaptor**

Part #	Description
TC-400	4" Torque Cap
H15144M	4" NPT Nipple, 4" Length
H12806M	4" NPT Nipple, 5" Length
VPN4X7	4" NPT Nipple, 7" Length
H15271M	4" NPT Nipple, 8" Length
H15268M	4" NPT Nipple, 10" Length

**Replacement Parts**

Part #	Description
1DK-2100-EVR	Drain Valve Kit
1-21AC	Aluminum Cover w/ Seal
1-21CC	Cast Iron Cover w/ Seal
H12229M	Cover Seal
1PPK-2100	Hand Pump & Plug Kit for 1-2100
1DP-2100	Replacement Drain Plug Kit for 1-2100

The following products are in compliance with California Water Resources Control Board (W.R.C.B.) for coating of buried metal components, such as stainless steel clamps or entire Spill Containment Bucket bottoms.

Part #	Description
SL-1100	Urethane Sealant (10.3 oz.)
W.R.C.B. approved CCR Title 23, Div. 16, Sec. 1631 & 2636	

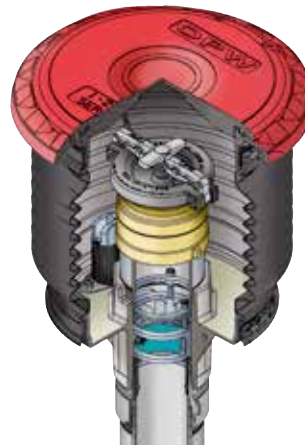

**1-2100-DEVR Series Product Fill Spill Container**

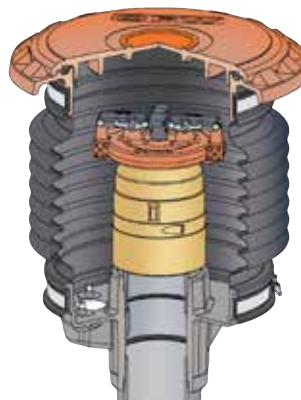
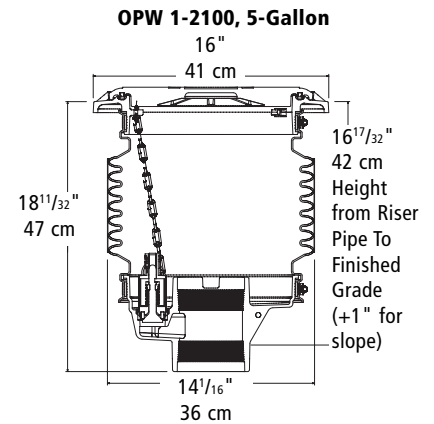

**1-2100-PEVR Series Vapor Recovery Spill Container**

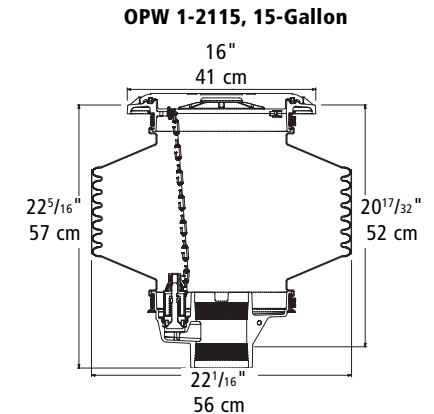

\*Subtract 2" from height dimension for Cast Iron Base Models.

NOTE: 20 17/32" dimension is height from riser pipe to finish grade (+1" for slope)

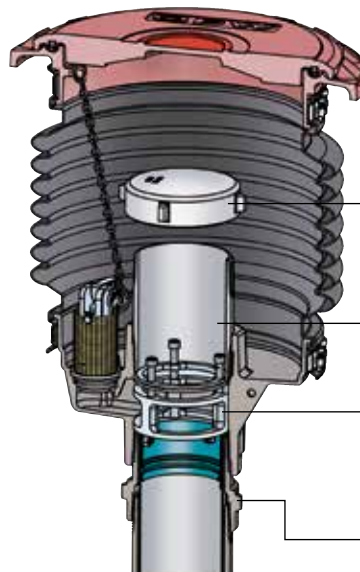

**TC-400 Torque Cap**

Provides an easy means of threading a 4" NPT nipple into a spill container. The OPW TC-400 coupled with the OPW 61SA-TOOL can provide the necessary torque requirements for installing adaptor nipples for spill containers. The TC-400 can easily be removed without disturbing the installed threaded nipple. The TC-400 also eliminates the need for a strap or chain wrench.

**4" Threaded Pipe Nipple**

OPW pipe nipples are CNC machined, providing a smooth sealing surface where a gasket seal exists. Available in various lengths to custom fit the necessary height requirements for Fill and Vapor Adaptors.

**61JSK Jack Screw Device**

See page 65 for detailed information.

**FSA-400 Face Seal Adaptor**

See page 65 for detailed information.