



DISPENSERS



FUEL KITS



PUMPS



METERS



NOZZLE



FILTRATION

# EX80CD

## FEATURES

- CONTINUOUS DUTY CYCLE
- THERMAL PROTECTION
- SUCTION UNIT WITH INTEGRATED FILTER
- HIGH FLOW RATE
- cULus CERTIFIED

The EX80CD is the first addition to the new line of heavy duty AC fuel pumps by PIUSI. This gasoline-specific, continuous duty, pump is built to perform! With a 3/4HP motor it achieves a true 20GPM flow at the nozzle, and can be used for gasoline, diesel or kerosene. Like other EX series pumps it also offers a detachable switch housing for a quick-and-easy remote option.

## PERFORMANCE

UP TO  
**20 GPM**

FLOW RATE

**AC**  
VOLTAGE

POWER



EX80CD



## PACKAGING

PART #	WEIGHT		PACKAGING		
	KG	LBS	MM	INCH	PCS/BOX
F00390400	28.12	62	457X457X457	18X18X18	1
F00391410	-	-	-	-	-
F00391400	-	-	-	-	-



FLUID  
MONITORING



AIR



ANTIFREEZE



DEF



BIODIESEL



DIESEL



FOOD



GASOLINE



GREASE



KEROSENE



OIL



WATER



WINDSCREEN

## CHART

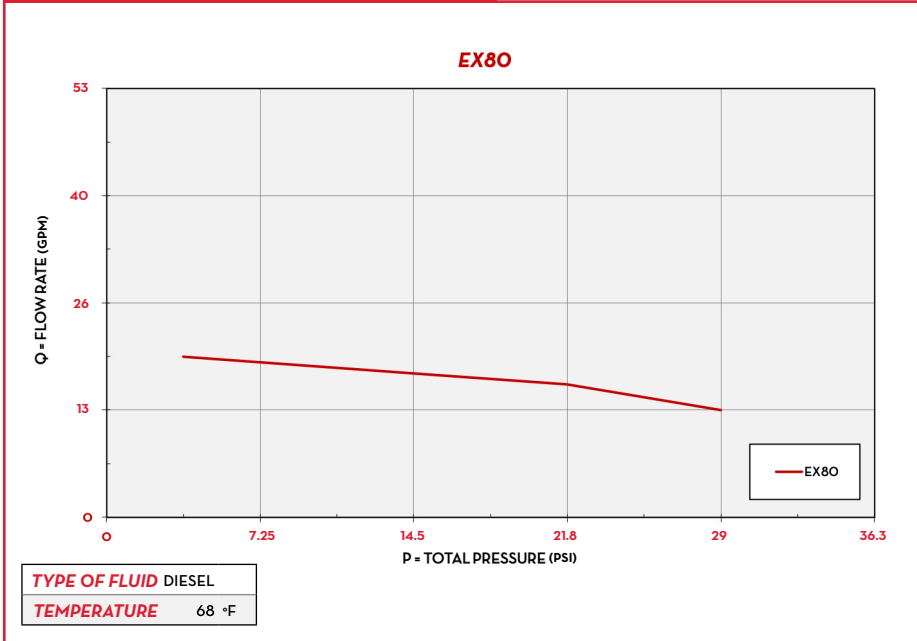

## IN THE BOX

- EX80 / EX80CD / EX100 / EX140 PUMPS
- NOZZLE HOLDER
- 1" 1/4 CONNECTOR
- 90° ELBOW
- INSTRUCTION MANUAL

## DETAILS



## DIMENSIONS

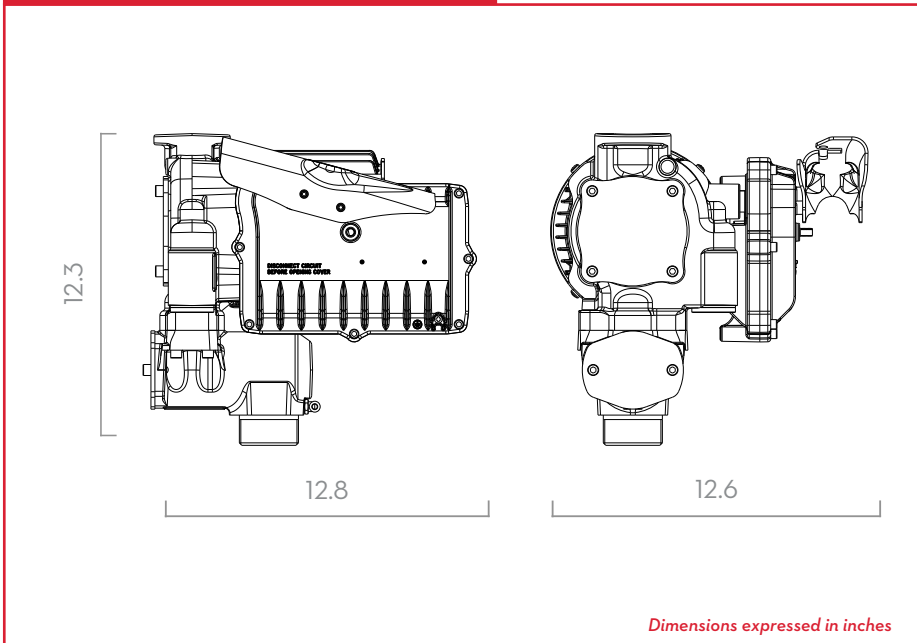

## MATERIALS

- BODY: CAST IRON
- ROTOR: SINTERED STEEL
- VANES: TECHNOPYLIMER
- SEAL: VITON
- SHAFT: STEEL

## TECHNICAL DATA

PART #	DESCRIPTION	FLUIDS TYPE	FLOW RATE		VOLTAGE			DUTY CYCLE		RPM	INLET		OUTLET	
			L/MIN	GPM	AC V/HZ	DC VOLT	POWER WATT	AMP. MAX.	MINUTES		NPT	NPT		
FO0390400	EX80CD 20GPM 120V (PUMP ONLY) CONTINUOUS DUTY	D G K	75	20	120/60		780	6.5	CONTINUOUS	1450	1" 1/4	1" 3/4" FLANGE		
FO0391410	(uL) EX80CD BASIC+ 120/60 NPT/UNC	D G K	75	20	120/60		780	6.5	CONTINUOUS	1450	1" 1/4	1" 3/4" FLANGE		
FO0391400	(uL) EX80CD K150 PRO 120/60 NPT/UNC	D G K	75	20	120/60		780	6.5	CONTINUOUS	1450	1" 1/4	1" 3/4" FLANGE		