

4" SUBMERSIBLE TURBINE PUMPS

Since hitting the market in 1988, FE PETRO® brand submersible pumps have developed a reputation as the standard in performance, quality and dependability with innovative features only available from Franklin Fueling Systems. It is, and always will be about filling cars faster. With best-in-class flow rates and backed by a long history of dependability, FE PETRO® pumps are responsible for delivering fuel to thousands of customers around the globe, day in and day out.

HIGHLIGHTS

Variable Speed

With faster fill times during peak hours and power savings during non-peak hours, variable speed submersible pumping systems allow you to maximize profits with consistent flow rates while mitigating operating expenses.

MagShell®

The patented stainless steel MagShell®, available on 2 Hp and 4 Hp pumps, is designed to maximize flow rate capabilities, potential throughput, and profits. By expanding the pump motor shell, the MagShell® increases the area for product flow by 45%.

Biofuel Blend Compatibility

FE PETRO® Alcohol-Gas (AG) and Advanced Protection (AP) pumps are UL listed with both UL79A (up to 85% Ethanol) and UL79B (up to 20% or 100% Biodiesel).

Variable Length

The patented telescoping pump shaft lets installers adjust the length of the pump onsite for the perfect fit.



Advanced Protection

Stop corrosion in its tracks. Special powder-coated, e-coated, and stainless steel components defend your pump in the tank and in the sump from accelerated corrosion.

Turbine Pump Interface

Remote enhanced pump monitoring and control including pump-in-water automation, clogged intake escalation, tank leveling, and tank priority.

Intake Filter Screen

Avoid system damage, pumping slowdowns, and reduce filter changes by keeping harmful tank debris, sediment, and corrosion from entering the pumping system with this factory-installed option.

FEATURE SELECTION

| | 4 HP | 2 HP | 1 1/2 HP | 1/3 3/4 HP |
|--------------------------|------|------|----------|------------|
| Variable Speed | ✓ | ✓ | | |
| Fixed Speed | | ✓ | ✓ | ✓ |
| MagShell® | ✓ | ✓ | | |
| Biofuel Compatibility* | ✓ | ✓ | ✓ | ✓ |
| Variable Length | ✓ | ✓ | ✓ | ✓ |
| Fixed Length | | ✓ | ✓ | ✓ |
| Advanced Protection | ✓ | ✓ | ✓ | ✓ |
| Turbine Pump Interface** | ✓ | ✓ | ✓ | ✓ |
| Intake Filter Screen | ✓ | ✓ | ✓ | ✓ |

*Up to 85% Ethanol and up to 20% or 100% Biodiesel.

**Fixed speed models require a Guardian Series™ Single Phase Smart Controller (SPGC-220) to network with EVO™ Series Automatic Tank Gauges.

SPECIFICATIONS

4" Submersible Pump Components & Key Dimensions

- 1 Manhole
- 2 Leak Detector
- 3 Manifold
- 4 Containment Sump
- 5 4" Riser
- 6 Tank Adapter
- 7 Tank Manway
- 8 Column Pipe
- 9 Variable Length Coupler
- 10 Pump Motor Assembly (PMA)
- 11 End Bell

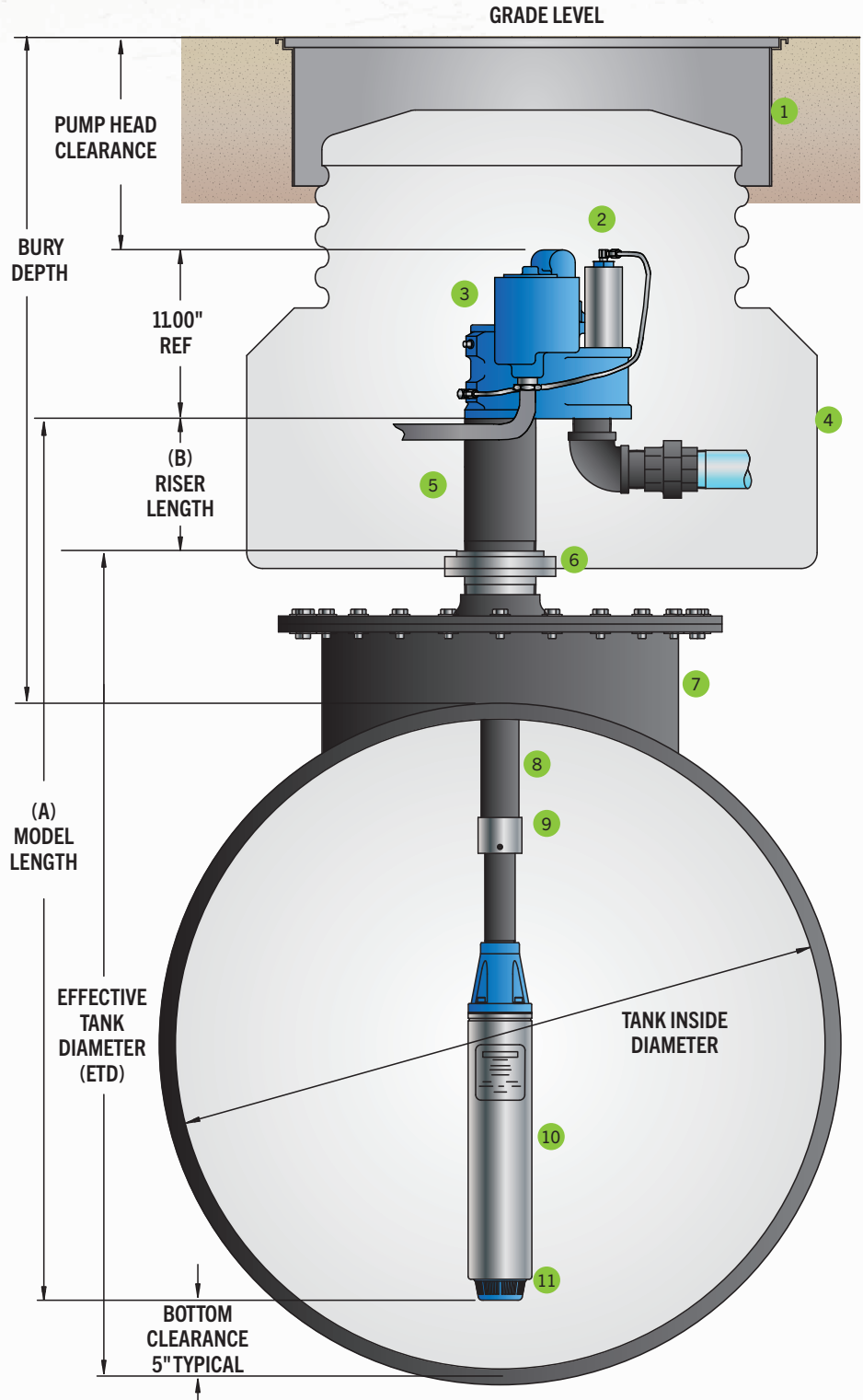

Notes:

1. Effective tank diameter (ETD) = Inside tank diameter (to top of 4" bung), including tank manway and/or sump adapter.
2. Model length (A) = ETD plus riser length minus bottom clearance minus 1" thread engagement.
3. Riser length (B) = Bury depth (to top of tank) minus pump head clearance minus tank manway and/or minus sump adapter.

SPECIFICATIONS CONTINUED

4" Submersible Pump Manifold Components & Key Dimensions

- | | | |
|------------------------------|-----------------------|----------------------------|
| 1 Line Test Port, ¼" NPT | 3 Syphon Port, ¼" NPT | 5 Riser Pipe, 4" NPT |
| 2 Leak Detector Port, 2" NPT | 4 Tank Port, ¼" NPT | 6 Discharge Outlet, 2" NPT |

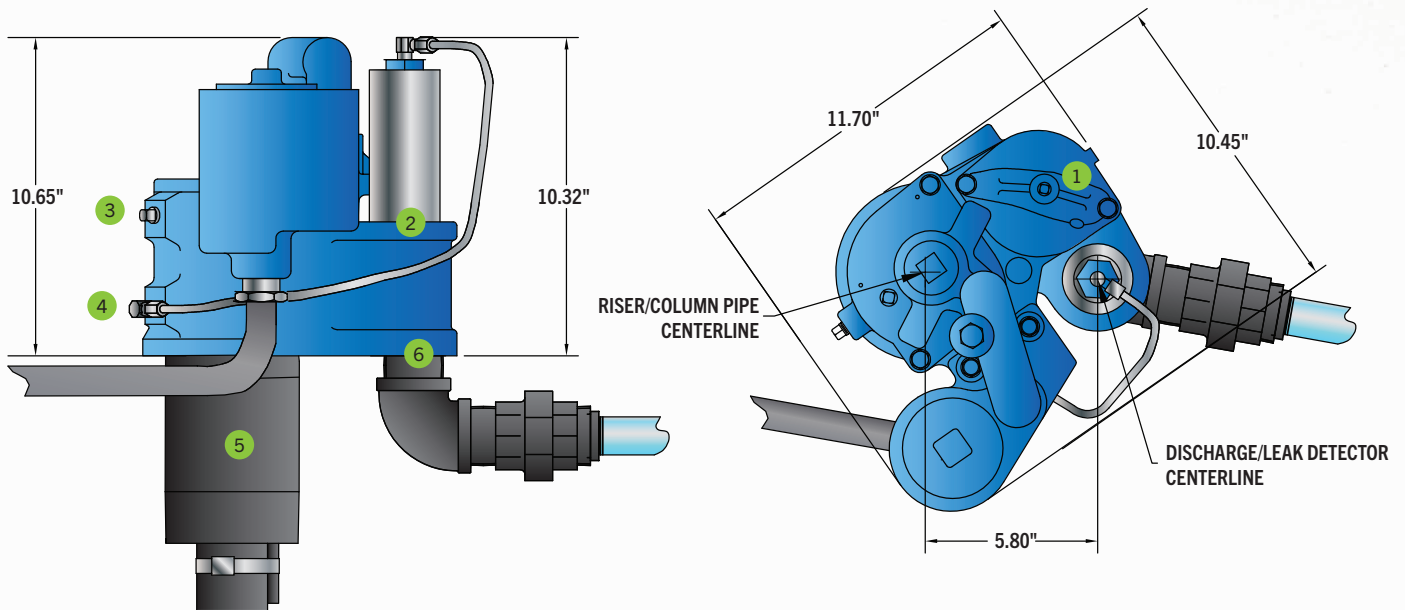

Fuel Compatibility for All Submersible Turbine Pumps

STP Standard Submersible Turbine Pumps with Fixed or Variable Speed Pump Motor Assembly

- UL79 for petroleum dispensing products intended for use with gasoline or gasoline/ethanol blends with nominal ethanol concentrations up to 10 percent (gasohol, E10), diesel fuel, diesel/biodiesel blends with nominal biodiesel concentrations up to 5 percent (B5), kerosene, or fuel oil.
- 20% MTBE, 20% ETBE or 17% TAME with gasoline.

STPAG, STPAP, IST, ISTAP Alcohol-Grade Compatible and Advanced Protection Fixed or Variable Speed Submersible Turbine Pumps

- UL79A for gasoline and gasoline/ethanol blends with nominal ethanol concentrations up to 85 percent (E0 - E85) for products intended for use with gasoline or gasoline/ethanol blends with nominal ethanol concentrations up to 85 percent (E85).
- 20% MTBE, 20% ETBE or 17% TAME with gasoline.
- UL79B for diesel fuel, biodiesel fuel, diesel/biodiesel blends with nominal biodiesel concentrations up to 20 percent (B20), kerosene, and fuel oil for products intended for use with diesel fuel, biodiesel fuel, diesel/biodiesel blends with nominal biodiesel concentrations up to 20 percent (B20), kerosene or fuel oil.
- 100% biodiesel.

4 HP SUBMERSIBLE TURBINE PUMPS

With faster fill times during peak hours and power savings during non-peak hours, FE PETRO® 4 Hp variable speed submersible pumps deliver maximized profits while mitigating operating expenses.



HIGHLIGHTS

OPTIONAL FEATURES

Biofuel Blend Compatibility

FE PETRO® pumps are UL listed with both UL79A (up to 85% Ethanol) and UL79B (up to 20% or 100% Biodiesel).

Advanced Protection

Stop corrosion in its tracks. Special powder-coated, e-coated, and stainless steel components defend your pump in the tank and in the sump from accelerated corrosion.

STANDARD FEATURES

Variable Speed

With faster fill times during peak hours and power savings during non-peak hours, variable speed submersible pumping systems allow you to maximize profits with consistent flow rates while mitigating operating expenses.

MagShell®

The patented stainless steel MagShell® is designed to maximize flow rate capabilities, potential throughput, and profits. By expanding the pump motor shell, the MagShell® increases the area for product flow by 45%.

Variable Length

The patented telescoping pump shaft lets installers adjust the length of the pump onsite for the perfect fit.

Active Air Eliminator

FE PETRO® STPs come standard with active air elimination, which eliminates air through the highest point in the pump head at all times when the pump is running, assuring air does not pass into discharge piping.

Safety and Ease of Maintenance

FE PETRO® STPs include a contractor electrical disconnect, which requires loosening only one bolt, allowing motor wiring to be disconnected without venting the dangerous tank vapors into the sump when servicing FE PETRO® submersible products.

Turbine Pump Interface

Remote enhanced pump monitoring and control including pump-in-water automation, clogged intake escalation, tank leveling, and tank priority.

Intake Filter Screen

Avoid system damage, pumping slowdowns, and reduce filter changes by keeping harmful tank debris, sediment, and corrosion from entering the pumping system with this factory-installed option.

Simple Servicing

If ever required, the pump can be easily removed from the tank by unthreading three bolts. There is no need to disconnect the syphon system or to remove the leak detector from the system to service the STP.

Manual Pressure Relief

As a standard FE PETRO® feature, a vent screw is provided to bleed line pressure to zero when necessary. By turning this screw, product is diverted back to the tank, dropping line pressure to zero. This reduces fuel discharged into the sump manhole or dispenser pan during servicing, further protecting service technicians and the environment.

Outlast, Outperform with Franklin Electric Inside

FE PETRO® STPs are powered by the legendary Franklin Electric motor and built for long term performance. Franklin Electric-powered submersible pumps provide maximum uptime and a proven track record in the fueling industry that spans more than four decades. They feature best-in-class flow rates and a long history of dependability.

Quality Certification

Franklin Fueling Systems is an ISO 9001 Certified Manufacturer.

SPECIFICATIONS

General

- Variable speed models are available in variable lengths only.
- Check valve: 2¾" diameter fluorocarbon seal constructed with cast aluminum body and steel backing washer.
- Pressure relief valve: available in four pressure relief settings, integral to check valve. Standard model relieves at 40 psi and resets above 35 psi.
- Syphon: venturi-type syphon primer supplied with every submersible. Syphon check valve and secondary syphon sold separately.
- Air eliminator: every submersible includes a tank return path with one-way check valve to provide active air elimination.
- Electrical disconnect: electrical yoke for positive contractor disconnect during service.

Pump Motor

- 4 Hp, variable speed, two-stage centrifugal type pump motor with integral, automatic, thermal overload protection.
- Max. pressure: selectable operating pressure on MagVFC™ between 24 psi and 42 psi deadhead.
- Available with MagShell® which results in 45% increased flow area around motor.

Approvals

- cULus listed.
- Consult factory for applicable approvals.

Power Requirements

- Variable speed pumps can only be controlled by a MagVFC™ variable frequency controller.
- VS4 models require three-phase incoming power supply to the MagVFC™ for proper operation.
- Incoming power supply to the MagVFC™ can be 200-250 VAC, 50 or 60 Hz.
- MagVFC™ outputs a three-phase, variable frequency signal, valid for FE PETRO® variable speed pumps only.
- MagVFC™ max. line draw: 20 Amps.
- Max motor draw: 15 Amps.

Liquid Compatibility

- Max. liquid viscosity: 70 SSU at 60 °F (15 °C).
- STP variable speed models are UL listed for fuel mixtures containing up to 10% ethanol, and 20% MTBE, 20% ETBE or 17% TAME with gasoline.
- IST/ISTAP variable speed models are UL and cUL listed for fuel mixtures containing diesel fuel with up to 20% Biodiesel, 100% Biodiesel, up to 85% ethanol with gasoline, and 20% MTBE, 20% ETBE or 17% TAME with gasoline.
- All variable speed models can also be used with diesel fuels, fuel oils, kerosene, Avgas and jet fuels in a non-gelled pourable state.
- All wetted elastomers are made of a high grade, fluorocarbon compound.

4 Hp Variable Speed Pump Performance Chart

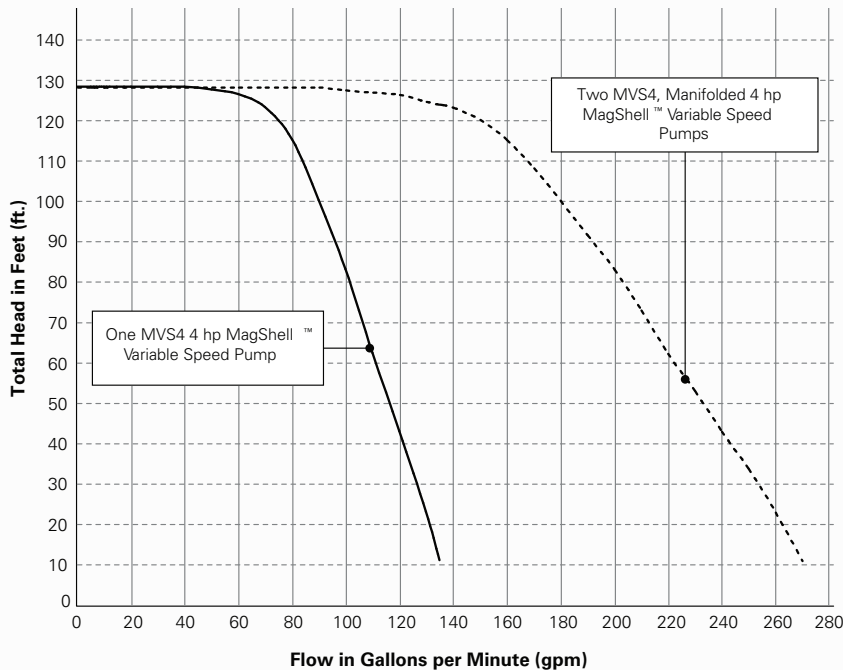

Note: Performance based on pumping gasoline (0.76 specific gravity). Pressure is taken at the manifold discharge outlet. ISTMVS4 and STPMVS4 turbines can only be powered by a MagVFC with three phase incoming power

ORDERING INFORMATION

4 Hp Submersible Pump Ordering Guide

A typical turbine model designation has up to five components to define the pump being supplied as follows:

XXX YYYYY Z - A - B

XXX = Basic Model Designation

STP = These standard variable speed and variable length models are capable of up to 10% ethanol with gasoline

IST = These variable speed and variable length models include alcohol-gasoline compatibility (up to 85% ethanol, up to 20% Biodiesel, or 100% Biodiesel).

ISTAP = These variable speed and variable length models include alcohol-gasoline compatibility (up to 85% ethanol, up to 20% Biodiesel, or 100% Biodiesel) and Advanced Protection with powder-coated, e-coated, and stainless steel components.

YYYYY = Factory Installed Options

Model designations may include one or more of the following characters in alphabetical order:

F = Floating suction adapter (1½" NPT female adapter)

K = Intake filter screen (IFS, factory installed to PMA)

M = MagShell® (flow enhancing, expanded PMA shell)

R* = Model R check valve (24 psi relief/22 psi reset for PLLD)

W* = Model W check valve (16 psi relief/13 psi reset for PPM4000)

Z = Pump Motor Horsepower Rating

VS4 = 4 Hp variable speed

A = Model Length (see table)

VL1 = STP variable length range #1

VL2 = STP variable length range #2

VL3 = STP variable length range #3

B = Riser Pipe Length (see diagram)

Riser pipe length is expressed as two numeric characters that indicate the total length of the riser in inches. Riser pipes are available from 7" to 60" in 1" increments (additional charge for risers 31" or longer).

Notes:

*If not otherwise specified, all models are supplied with standard model check valve (40 psi relief / 35 psi reset for MLD, TS-LS300, and TS-LS500).

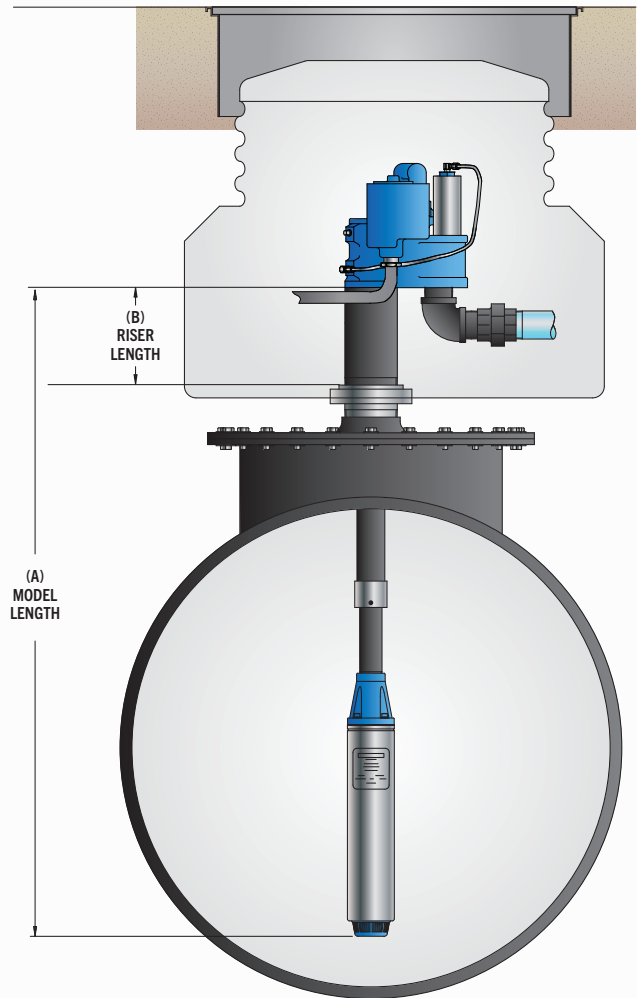

Model Length (A)

| STP Horsepower | Model Length Range | Model Length Designation |
|----------------|--------------------|--------------------------|
| 4 Hp | 64" – 92" | VL1 |
| | 95" – 156" | VL2 |
| | 127" – 218" | VL3 |

ORDERING INFORMATION CONTINUED

4 Hp Variable Speed Submersible Turbine Pumps

Variable speed, variable length.

| Model | Description | Model Length Range Number | Model Length Range* |
|-------------|------------------------------------|---------------------------|---------------------|
| STPMVS4-VL1 | 4 Hp variable speed with MagShell® | VL1 | 64" – 92" |
| STPMVS4-VL2 | 4 Hp variable speed with MagShell® | VL2 | 95" – 156" |
| STPMVS4-VL3 | 4 Hp variable speed with MagShell® | VL3 | 127" – 218" |

4 Hp Variable Speed Intelligent Submersible Turbine Pumps

Variable speed, variable length, and AG compatible.

| Model | Description | Model Length Range Number | Model Length Range* |
|---------------|--|---------------------------|---------------------|
| ISTMVS4-VL1 | 4 Hp AG variable speed with MagShell® | VL1 | 64" – 92" |
| ISTMVS4-VL2 | 4 Hp AG variable speed with MagShell® | VL2 | 95" – 156" |
| ISTMVS4-VL3 | 4 Hp AG variable speed with MagShell® | VL3 | 127" – 218" |
| ISTAPMVS4-VL1 | 4 Hp AG variable speed with Advanced Protection, and MagShell® | VL1 | 64" – 92" |
| ISTAPMVS4-VL2 | 4 Hp AG variable speed with Advanced Protection, and MagShell® | VL2 | 95" – 156" |
| ISTAPMVS4-VL3 | 4 Hp AG variable speed with Advanced Protection, and MagShell® | VL3 | 127" – 218" |

Notes:

1. Remove "M" from model number for non-MagShell® pump motor assembly.
 2. All STP models are UL and cUL listed for compatibility with fuel mixtures containing up to 10% ethanol with gasoline, up to 5% Biodiesel with diesel fuels, and 20% MTBE, 20% ETBE or 17% TAME with gasoline.
 3. All IST/ISTAP models are compatible with fuel mixtures containing diesel fuel with up to 20% Biodiesel, 100% Biodiesel, up to 85% ethanol with gasoline, and 20% MTBE, 20% ETBE or 17% TAME with gasoline.
 4. All models are supplied with a standard check valve unless factory option "R" or "W" is specified.
 5. All above models can only be powered by a MagVFC™. 4 hp models require three-phase incoming power supply, 2 hp models can be supplied with single- or three-phase incoming power.
 6. 4" riser pipe, if supplied locally, must be 4½" OD by ¾" WT tubing.
 7. For riser pipe length 31" to 60", additional charge applies (call Customer Service for lead times).
- *Model length (A) defined as the dimension from turbine manifold bottom to pump motor inlet.

Factory Installed Options

Specified in model number at time of STP order.

| Model | Description |
|-------|--|
| F | Floating suction adapter, 1½" NPT female, must be factory installed |
| K | IFS (intake filter screen) factory assembled to pump motor assembly |
| R | Model R check valve, factory installed, for Veeder-Root® PLLD Line Leak |
| W | Model W check valve, factory installed, for Red Jacket PPM4000 Line Leak |

Field Installed Options

Intelligent submersible turbine pump specific accessories.

| Model | Description |
|------------|--|
| 5874202800 | MagVFC™, 2 Hp or 4 Hp variable frequency controller, one required per STPM VS2 or VS4 |
| 400137908 | Syphon check valve, alcohol-gasoline compatible (when ordered with STPM VS2 or VS4) |
| 402459931 | Model 65 psi check valve AG compatible, (for secondary of manifolded STPM VS2 or VS4 with Veeder-Root® PLLD) |
| 402507930 | Secondary syphon kit (when two syphon primes are required for one STPM VS2 or VS4) |
| 5800300100 | STP-DHI dispenser hook isolation for 120 Volt dispenser handle switches, up to eight each |

2 HP SUBMERSIBLE TURBINE PUMPS

With faster fill times during peak hours and power savings during non-peak hours, FE PETRO® 2 Hp variable speed submersible pumps deliver maximized profits while mitigating operating expenses. 2 Hp submersible pumps are also available in fixed speed models.

HIGHLIGHTS

OPTIONAL FEATURES

Variable Speed

With faster fill times during peak hours and power savings during non-peak hours, variable speed submersible pumping systems allow you to maximize profits with consistent flow rates while mitigating operating expenses.

Biofuel Blend Compatibility

FE PETRO® pumps are UL listed with both UL79A (up to 85% Ethanol) and UL79B (up to 20% or 100% Biodiesel).

Advanced Protection

Stop corrosion in its tracks. Special powder-coated, e-coated, and stainless steel components defend your pump in the tank and in the sump from accelerated corrosion.

STANDARD FEATURES

MagShell®

The patented stainless steel MagShell® is designed to maximize flow rate capabilities, potential throughput, and profits. By expanding the pump motor shell, the MagShell® increases the area for product flow by 45%.

Variable Length

The patented telescoping pump shaft lets installers adjust the length of the pump onsite for the perfect fit.

Active Air Eliminator

FE PETRO® STPs come standard with active air elimination, which eliminates air through the highest point in the pump head at all times when the pump is running, assuring air does not pass into discharge piping.

Safety and Ease of Maintenance

FE PETRO® STPs include a contractor electrical disconnect, which requires loosening only one bolt, allowing motor wiring to be disconnected without venting the dangerous tank vapors into the sump when servicing FE PETRO® submersible products.



Turbine Pump Interface

Remote enhanced pump monitoring and control including pump-in-water automation, clogged intake escalation, tank leveling, and tank priority.

Intake Filter Screen

Avoid system damage, pumping slowdowns, and reduce filter changes by keeping harmful tank debris, sediment, and corrosion from entering the pumping system with this factory-installed option.

Simple Servicing

If ever required, the pump can be easily removed from the tank by unthreading three bolts. There is no need to disconnect the syphon system or to remove the leak detector from the system to service the STP.

Manual Pressure Relief

As a standard FE PETRO® feature, a vent screw is provided to bleed line pressure to zero when necessary. By turning this screw, product is diverted back to the tank, dropping line pressure to zero. This reduces fuel discharged into the sump manhole or dispenser pan during servicing, further protecting service technicians and the environment.

Outlast, Outperform with Franklin Electric Inside

FE PETRO® STPs are powered by the legendary Franklin Electric motor and built for long term performance. Franklin Electric-powered submersible pumps provide maximum uptime and a proven track record in the fueling industry that spans more than four decades. They feature best-in-class flow rates and a long history of dependability.

Quality Certification

Franklin Fueling Systems is an ISO 9001 Certified Manufacturer.

SPECIFICATIONS

General

- Variable speed models are available in variable lengths only.
- Fixed speed models are available in variable length and fixed length options.
- Check valve: 2¾" diameter fluorocarbon seal constructed with cast aluminum body and steel backing washer.
- Pressure relief valve: available in four pressure relief settings, integral to check valve. Standard model relieves at 40 psi and resets above 35 psi.
- Syphon: venturi-type syphon primer supplied with every submersible. Syphon check valve and secondary syphon sold separately.
- Air eliminator: every submersible includes a tank return path with one-way check valve to provide active air elimination.
- Electrical disconnect: electrical yoke for positive contractor disconnect during service.

Variable Speed Pump Motor

- 2 Hp, variable speed, two-stage centrifugal type pump motor with integral, automatic, thermal overload protection.
- Max. pressure: selectable operating pressure on MagVFC™ between 24 psi and 42 psi deadhead.
- Available with MagShell® which results in 45% increased flow area around motor.

Fixed Speed Pump Motor

- 2 Hp fixed speed, 3450 rpm, multi-stage centrifugal type pump motor with integral, automatic, thermal overload protection.
- Standard pressure (M200, two-stage) model, max. pressure = 36 psi.
- High pressure (HM200, three-stage) model, max. pressure = 45 psi.
- Available with MagShell™ for 45% increased flow area around motor.

Approvals

- cULus listed.
- Consult factory for applicable approvals.

Liquid Compatibility

- Max. liquid viscosity: 70 SSU at 60 °F (15 °C).
- STP variable speed models are UL and cUL listed for fuel mixtures containing up to 10% ethanol, and 20% MTBE, 20% ETBE or 17% TAME with gasoline.
- STPAG (AG compatible) models are UL listed for fuel mixtures containing diesel fuel with up to 20% Biodiesel, 100% Biodiesel, up to 85% ethanol with gasoline, and 20% MTBE, 20% ETBE or 17% TAME with gasoline.
- All variable speed (non-AG) models can also be used with diesel fuels, fuel oils, kerosene, Avgas and jet fuels in a non-gelled pourable state.
- 2 Hp fixed speed models can also be used with diesel fuels, fuel oils, kerosene, Avgas and jet fuels in a non-gelled pourable state.
- All wetted elastomers are made of a high grade, fluorocarbon compound.

Variable Speed Power Requirements

- Variable speed pumps can only be controlled by a MagVFC™ variable frequency controller.
- VS2 models can operate with single- or three-phase incoming power supply to the MagVFC™.
- Incoming power supply to the MagVFC™ can be 200-250 VAC, 50 or 60 Hz.
- MagVFC™ outputs a three-phase, variable frequency signal, valid for FE PETRO® variable speed pumps only.
- MagVFC™ max. line draw: 20 Amps.
- Max motor draw: 7 Amps.

Fixed Speed Power Requirements

- 2 Hp fixed speed models require single-phase, 208-230 VAC, 60 Hz incoming power.
- 2 Hp fixed speed models incorporate a starting and running capacitor, with internal bleed resistor, rated 370 Volt, 40 microfarad.
- STP-SCI single-phase Smart Controllers and STP-CBS single-phase control boxes are available for 2 hp pump control.
- Max. motor draw: 12 Amps.

SPECIFICATIONS CONTINUED

2 Hp Variable Speed Pump Performance Chart

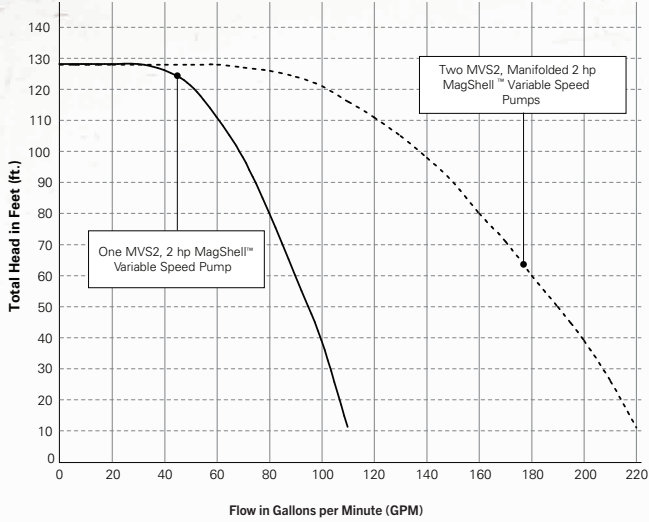

Performance based on pumping gasoline (0.76 specific gravity). Pressure is taken at the manifold discharge outlet. ISTM and STPMVS2 turbines can only be powered by a MagVFC with single or three phase incoming power.

2 Hp Fixed Speed Pump Performance Chart

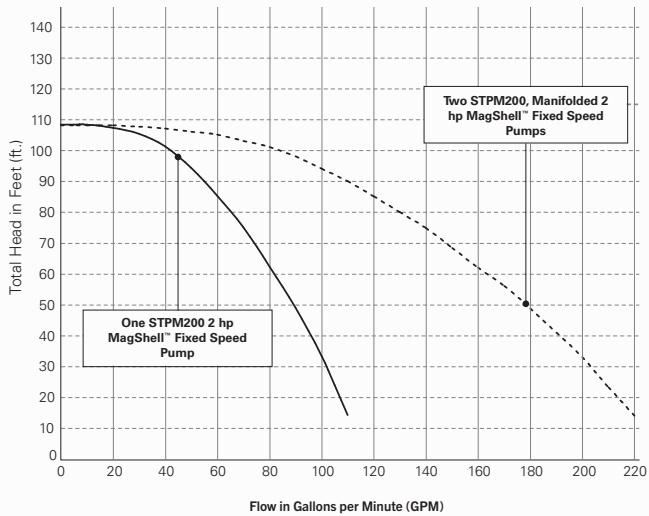

Performance based on pumping gasoline (0.78 specific gravity). Pressure is taken at the manifold discharge outlet. STPM200 are powered by a single-phase, 60 Hz, 208/230 Volt power supply.

2 Hp High Pressure Fixed Speed Pump Performance Chart

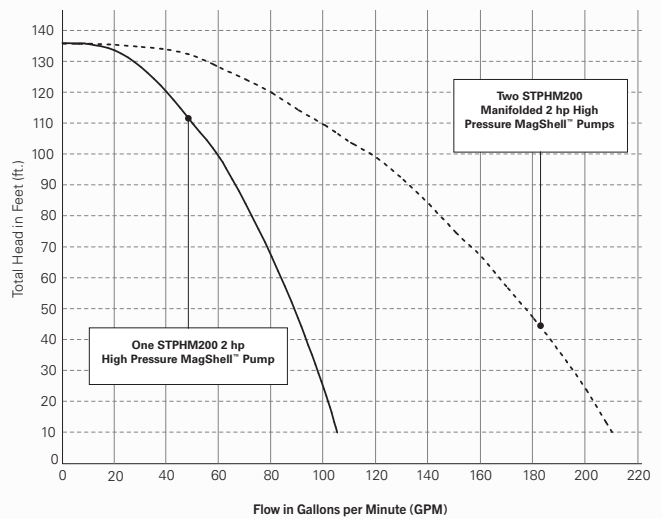

Performance based on pumping gasoline (0.78 specific gravity). Pressure is taken at the manifold discharge outlet. STPHM200 are powered by a single-phase, 60 Hz, 208/230 Volt power supply.

ORDERING INFORMATION

2 Hp Variable Speed Submersible Pump Ordering Guide

A typical model designation has up to five components to define the pump being supplied as follows:

XXX YYYY Z - A - B

XXX = Basic Model Designation

STP = These standard variable speed and variable length models are capable of up to 10% ethanol with gasoline

IST** = These variable speed and variable length models include alcohol-gasoline compatibility (up to 85% ethanol, up to 20% Biodiesel, or 100% Biodiesel).

ISTAP** = These variable speed and variable length models include alcohol-gasoline compatibility (up to 85% ethanol, up to 20% Biodiesel, or 100% Biodiesel) and Advanced Protection with powder-coated, e-coated, and stainless steel components.

YYYY = Factory Installed Options

Model designations may include one or more of the following characters:

F = Floating suction adapter (1½" NPT female adapter)

K = Intake filter screen (IFS, factory installed to PMA)

M = MagShell® (flow enhancing, expanded PMA shell)

R* = Model R check valve (24 psi relief/22 psi reset for PLLD)

W* = Model W check valve (16 psi relief/13 psi reset for PPM4000)

Z = Pump Motor Horsepower Rating

VS2 = 2 Hp variable speed

A = Model Length (see table)

VL1 = STP variable length range #1

VL2 = STP variable length range #2

VL3 = STP variable length range #3

B = Riser Pipe Length (see diagram)

Riser pipe length is expressed as two numeric characters that indicate the total length of the riser in inches. Riser pipes are available from 7" to 60" in 1" increments (additional charge for risers 31" or longer).

Notes:

*If not otherwise specified, all models are supplied with standard model check valve (40 psi relief / 35 psi reset for MLD, TS-LS300, and TS-LS500).

**If not otherwise specified, 2 Hp variable speed pump motor horsepower rating is implied for IST models.

2 Hp Fixed Speed Submersible Pump Ordering Guide

A typical model designation has up to five components to define the pump being supplied as follows:

STP XXXXX Y - A - B

STP = Basic Model Designation

XXXXX = Factory Installed Options

Model designations may include one or more of the following characters:

AP = Advanced Protection with powder-coated, e-coated, and stainless steel components, alcohol-gasoline compatible (up to E85, up to B20, and B100) (Note standard models up to 10% ethanol capable)

AG = Alcohol-gasoline compatible (up to E85, up to B20, and B100) (Note standard models up to 10% ethanol capable)

F = Floating suction adapter (1½" NPT female adapter)

K = Intake filter screen (IFS, factory installed to PMA)

M = MagShell® (flow enhancing, expanded PMA shell)

*R = Model R check valve (24 psi relief / 22 psi reset for PLLD)

*W = Model W check valve (16 psi relief / 13 psi reset for PPM4000)

Y = Pump Motor Horsepower Rating

200 = 2 Hp fixed speed

A = Model Length (see table)

VL1 = Variable length range #1

VL2 = Variable length range #2

VL3 = Variable length range #3

(Note VL2 models fit 94% of all known installations)

B = Riser Pipe Length (see diagram)

Riser pipe length is expressed as two numeric characters that indicate the total length of the riser in inches. Riser pipes are available from 7" to 60" in 1" increments (additional charge for risers 31" or longer).

Model Length (A)

| STP Horsepower | Model Length Range | Model Length Designation |
|--------------------------------|--------------------|--------------------------|
| 2 Hp Variable Speed | 59" – 87" | VL1 |
| | 90" – 151" | VL2 |
| | 122" – 213" | VL3 |
| 2 Hp Fixed Speed | 63" – 92" | VL1 |
| | 94" – 154" | VL2 |
| | 126" – 218" | VL3 |
| 2 Hp Fixed Speed High Pressure | 63" – 92" | VL1 |
| | 94" – 155" | VL2 |
| | 126" – 218" | VL3 |

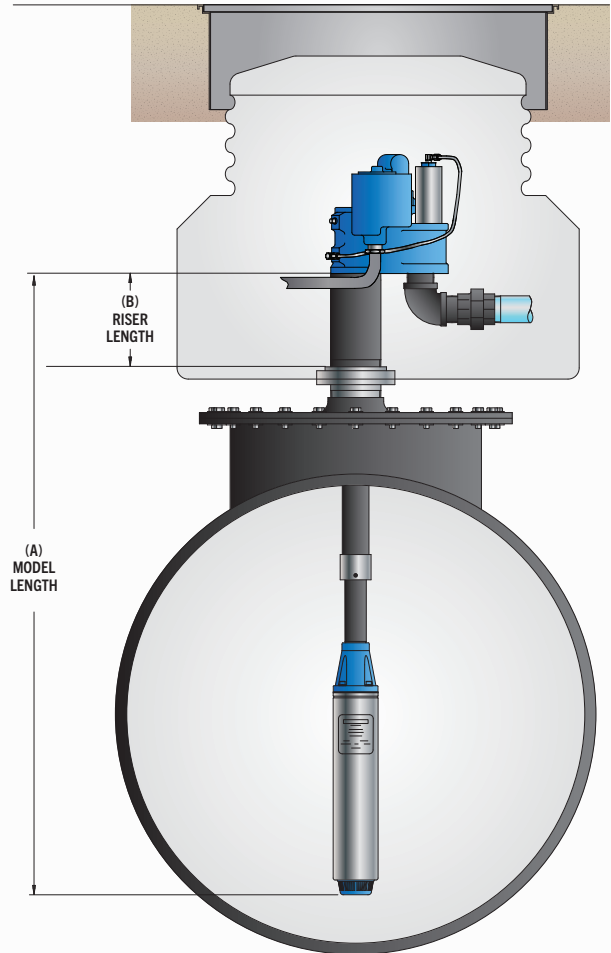

Notes: *If not otherwise specified, all STP models are supplied with standard model check valve (40 psi relief / 35 psi reset for MLD, TS-LS300, and TS-LS500).

ORDERING INFORMATION

2 Hp Variable Speed Submersible Turbine Pumps

Variable speed, variable length.

| Model | Description | Model Length Range Number | Model Length Range* |
|-------------|------------------------------------|---------------------------|---------------------|
| STPMVS2-VL1 | 2 Hp variable speed with MagShell® | VL1 | 59" – 87" |
| STPMVS2-VL2 | 2 Hp variable speed with MagShell® | VL2 | 90" – 151" |
| STPMVS2-VL3 | 2 Hp variable speed with MagShell® | VL3 | 122" – 213" |

2 Hp Variable Speed Intelligent Submersible Turbine Pumps

Variable speed, variable length, and AG compatible.

| Model | Description | Model Length Range Number | Model Length Range* |
|----------|--|---------------------------|---------------------|
| ISTM-1 | 2 Hp AG variable speed with MagShell® | VL1 | 59" – 87" |
| ISTM-2 | 2 Hp AG variable speed with MagShell® | VL2 | 90" – 151" |
| ISTM-3 | 2 Hp AG variable speed with MagShell® | VL3 | 122" – 213" |
| ISTAPM-1 | 2 Hp AG variable speed with Advanced Protection, and MagShell® | VL1 | 59" – 87" |
| ISTAPM-2 | 2 Hp AG variable speed with Advanced Protection, and MagShell® | VL2 | 90" – 151" |
| ISTAPM-3 | 2 Hp AG variable speed with Advanced Protection, and MagShell® | VL3 | 122" – 213" |

Standard 2 Hp Fixed Speed Submersible Turbine Pumps

| Model | Description | Model Length Range Number | Model Length Range* |
|--------------|---|---------------------------|---------------------|
| STPM200-VL1 | 2 Hp fixed speed with MagShell® | VL1 | 63" – 91" |
| STPM200-VL2 | 2 Hp fixed speed with MagShell® | VL2 | 94" – 154" |
| STPM200-VL3 | 2 Hp fixed speed with MagShell® | VL3 | 126" – 217" |
| STPHM200-VL1 | 2 Hp high pressure fixed speed with MagShell® | VL1 | 63" – 92" |
| STPHM200-VL2 | 2 Hp high pressure fixed speed with MagShell® | VL2 | 94" – 155" |
| STPHM200-VL3 | 2 Hp high pressure fixed speed with MagShell® | VL3 | 126" – 218" |

Alcohol-Gas (AG) 2 Hp Fixed Speed Submersible Turbine Pumps

| Model | Description | Model Length Range Number | Model Length Range* |
|----------------|--|---------------------------|---------------------|
| STPAGM200-VL1 | 2 Hp AG fixed speed with MagShell® | VL1 | 63" – 91" |
| STPAGM200-VL2 | 2 Hp AG fixed speed with MagShell® | VL2 | 94" – 154" |
| STPAGM200-VL3 | 2 Hp AG fixed speed with MagShell® | VL3 | 126" – 217" |
| STPAGHM200-VL1 | 2 Hp AG high pressure fixed speed with MagShell® | VL1 | 63" – 92" |
| STPAGHM200-VL2 | 2 Hp AG high pressure fixed speed with MagShell® | VL2 | 94" – 155" |
| STPAGHM200-VL3 | 2 Hp AG high pressure fixed speed with MagShell® | VL3 | 126" – 218" |
| STPAPM200-VL1 | 2 Hp fixed speed with Advanced Protection, and MagShell® | VL1 | 63" – 91" |
| STPAPM200-VL2 | 2 Hp fixed speed with Advanced Protection, and MagShell® | VL2 | 94" – 154" |
| STPAPM200-VL3 | 2 Hp fixed speed with Advanced Protection, and MagShell® | VL3 | 126" – 217" |
| STPAPHM200-VL1 | 2 Hp high pressure fixed speed with Advanced Protection, and MagShell® | VL1 | 63" – 92" |
| STPAPHM200-VL2 | 2 Hp high pressure fixed speed with Advanced Protection, and MagShell® | VL2 | 94" – 155" |
| STPAPHM200-VL3 | 2 Hp high pressure fixed speed with Advanced Protection, and MagShell® | VL3 | 126" – 218" |

Notes:

1. Remove "M" from model number for non-MagShell® pump motor assembly.
2. STP models are compatible with fuel mixtures containing up to 10% ethanol with gasoline, up to 5% Biodiesel with diesel fuels, and 20% MTBE, 20% ETBE or 17% TAME with gasoline. STPAG/STPAP models are compatible with fuel mixtures containing diesel fuel with up to 20% Biodiesel, 100% Biodiesel, up to 85% ethanol with gasoline, and 20% MTBE, 20% ETBE or 17% TAME with gasoline.
3. All models are supplied with a standard check valve unless factory option "R" or "W" is specified.
4. All above models require single-phase, 208-230 VAC, 60 Hz incoming power.
5. 4" riser pipe, if supplied locally, must be 4½" OD by ¾" WT tubing.
6. For riser pipe lengths 31" to 60", additional charges apply (call Customer Service for lead times).
7. All above IST and STPMVS2 models can only be powered by a MagVFC. MagVFC must be supplied with single- or three-phase incoming power for all above models.

*Model length (A) defined as the dimension from turbine manifold bottom to pump motor inlet.

ORDERING INFORMATION CONTINUED

Factory Installed Options

Specified in model number at time of STP order.

| Model | Description |
|-------|--|
| F | Floating suction adapter, 1½" NPT female, must be factory installed |
| K | IFS (intake filter screen) factory assembled to pump motor assembly |
| R | Model R check valve, factory installed, for Veeder-Root® PLLD Line Leak |
| W | Model W check valve, factory installed, for Red Jacket PPM4000 Line Leak |

Field Installed Options

2 Hp submersible pump specific accessories.

| Model | Description |
|------------|---|
| 400137908 | Syphon check valve, alcohol-gasoline compatible (when ordered with STP) |
| 5874202800 | MagVFC™, 2 hp or 4 hp variable frequency controller, one required per STPM VS2 or VS4 |
| 400818921 | STP-CBS, single-phase control box with lockout switch, 120 Volt coil |
| 402312931 | STP-DHI + SPGC-220 Guardian Series™ Single Phase Smart Controller bundle |
| 402313921 | STP-DHI-CBS, combo DHI with factory-wired STP-CBS |
| 402459931 | Model 65 psi check valve AG compatible, (for secondary of manifolded STPs with Veeder-Root® PLLD) |
| 402507930 | Secondary syphon kit (when two syphon primes are required for one STP) |
| 5800100220 | SPGC-220 Guardian Series™ Single Phase Smart Controller |
| 5800300100 | STP-DHI, dispenser hook isolation for 120 Volt dispenser handle switches, up to eight each |

1½ HP SUBMERSIBLE TURBINE PUMPS

FE PETRO® 1½ Hp fixed speed submersible pumps deliver consistent flow rates for medium throughput fuels.



HIGHLIGHTS

OPTIONAL FEATURES

Biofuel Blend Compatibility

FE PETRO® pumps are UL listed with both UL79A (up to 85% Ethanol) and UL79B (up to 20% or 100% Biodiesel).

Variable Length

The patented telescoping pump shaft lets installers adjust the length of the pump onsite for the perfect fit.

Advanced Protection

Stop corrosion in its tracks. Special powder-coated, e-coated, and stainless steel components defend your pump in the tank and in the sump from accelerated corrosion.

STANDARD FEATURES

Active Air Eliminator

FE PETRO® STPs come standard with active air elimination, which eliminates air through the highest point in the pump head at all times when the pump is running, assuring air does not pass into discharge piping.

Safety and Ease of Maintenance

FE PETRO® STPs include a contractor electrical disconnect, which requires loosening only one bolt, allowing motor wiring to be disconnected without venting the dangerous tank vapors into the sump when servicing FE PETRO® submersible products.

Simple Servicing

If ever required, the pump can be easily removed from the tank by unthreading three bolts. There is no need to disconnect the syphon system or to remove the leak detector from the system to service the STP.

Turbine Pump Interface

Remote enhanced pump monitoring and control including pump-in-water automation, clogged intake escalation, tank leveling, and tank priority.

Intake Filter Screen

Avoid system damage, pumping slowdowns, and reduce filter changes by keeping harmful tank debris, sediment, and corrosion from entering the pumping system with this factory-installed option.

Manual Pressure Relief

As a standard FE PETRO® feature, a vent screw is provided to bleed line pressure to zero when necessary. By turning this screw, product is diverted back to the tank, dropping line pressure to zero. This reduces fuel discharged into the sump manhole or dispenser pan during servicing, further protecting service technicians and the environment.

Outlast, Outperform with Franklin Electric Inside

FE PETRO® STPs are powered by the legendary Franklin Electric motor and built for long term performance. Franklin Electric-powered submersible pumps provide maximum uptime and a proven track record in the fueling industry that spans more than four decades. They feature best-in-class flow rates and a long history of dependability.

Quality Certification

Franklin Fueling Systems is an ISO 9001 Certified Manufacturer.

SPECIFICATIONS

General

- 1½ Hp fixed speed models are available in variable length and fixed length options.
- Check valve: 2¾" diameter fluorocarbon seal constructed with cast aluminum body and steel backing washer.
- Pressure relief valve: available in four pressure relief settings, integral to check valve. Standard model relieves at 40 psi and resets above 35 psi.
- Syphon: venturi-type syphon primer supplied with every submersible. Syphon check valve and secondary syphon sold separately.
- Air eliminator: every submersible includes a tank return path with one-way check valve to provide active air elimination.
- Electrical disconnect: electrical yoke for positive contractor disconnect during service.

Pump Motor

- 1½ Hp fixed speed, 3450 rpm, multi-stage centrifugal type pump motor with integral, automatic, thermal overload protection.
- Standard pressure (150, two-stage) model, max. pressure = 32 psi.
- High pressure (H150, three-stage) model, max. pressure = 45 psi.

Approvals

- cULus listed.
- Consult factory for applicable approvals.

Power Requirements

- 1½ Hp fixed speed models require single-phase, 208-230 VAC, 60 Hz incoming power.
- 1½ Hp fixed speed models incorporate a starting and running capacitor, with internal bleed resistor, rated 370 Volt, 15 microfarad.
- STP-SCI single-phase Smart Controllers and STP-CBS single-phase control boxes are available for 1½ Hp pump control.
- Max. motor draw: 11 Amps.

Liquid Compatibility

- Max. liquid viscosity: 70 SSU at 60 °F (15 °C).
- Standard STP models are UL and cUL listed for fuel mixtures containing up to 10% ethanol with gasoline, and 20% MTBE, 20% ETBE or 17% TAME with gasoline.
- STPAP/STPAG (AG compatible) models are UL listed for fuel mixtures containing diesel fuel with up to 20% Biodiesel, 100% Biodiesel, up to 85% ethanol with gasoline, and 20% MTBE, 20% ETBE or 17% TAME with gasoline.
- 1½ Hp fixed speed models can also be used with diesel fuels, fuel oils, kerosene, Avgas, and jet fuels in a non-gelled pourable state.
- All wetted elastomers are made of a high grade, fluorocarbon compound.

1½ Hp Fixed Speed Pump Performance Chart

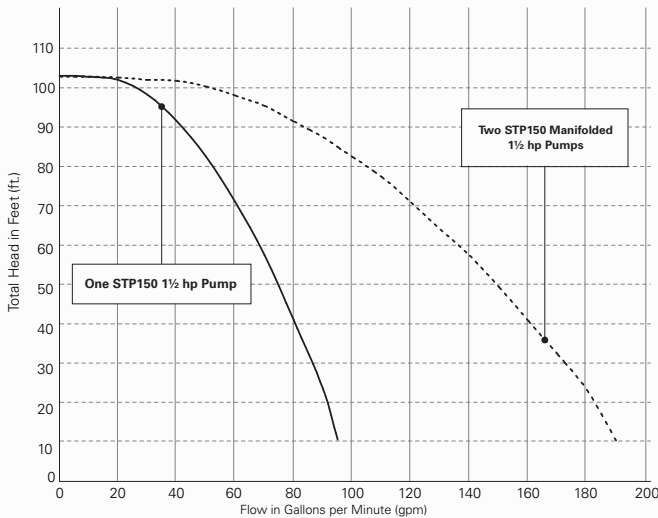

Note: Performance based on pumping gasoline (0.78 specific gravity). Pressure is taken at the manifold discharge outlet. STP150 models are powered by a single-phase, 60 Hz, 208/230 Volt power supply.

1½ Hp High Pressure Fixed Speed Pump Performance Chart

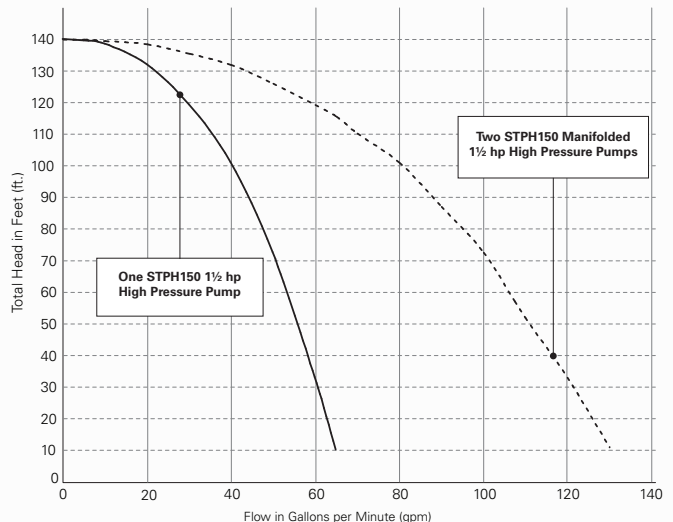

Note: Performance based on pumping gasoline (0.78 specific gravity). Pressure is taken at the manifold discharge outlet. STPH150 models are powered by a single-phase, 60 Hz, 208/230 Volt power supply.

ORDERING INFORMATION

1½ Hp Fixed Speed Submersible Pump Ordering Guide

A typical turbine model designation has up to five components to define the pump being supplied as follows:

STP XXXXX Y - A - B

STP = Basic Model Designation

XXXXX = Factory Installed Options (Model designations may include one or more of the following characters in alphabetical order.)

AP = Advanced Protection with powder-coated, e-coated, and stainless steel components, alcohol-gasoline compatible (up to E85, up to B20, and B100) (Note standard models up to 10% ethanol capable)

AG = Alcohol-gasoline compatible (up to E85, up to B20, and B100) (Note standard models up to 10% ethanol capable)

F = Floating suction adapter (1½" NPT female adapter)

K = Intake filter screen (IFS, factory installed to PMA)

*R = Model R check valve (24 psi relief / 22 psi reset for PLLD)

*W = Model W check valve (16 psi relief / 13 psi reset for PPM4000)

Y = Pump Motor Horsepower Rating

150 = 1½ hp fixed speed

A = Model Length (see table)

VL1 = Variable length range #1.

VL2 = Variable length range #2.

VL3 = Variable length range #3.

(Note VL2 models fit 94% of all known installations)

B = Riser Pipe Length (see diagram)

Riser pipe length is expressed as two numeric characters that indicate the total length of the riser in inches. Riser pipes are available from 7" to 60" in 1" increments (additional charge for risers 31" or longer).

*Notes: *If not otherwise specified, all STP models are supplied with standard model check valve (40 psi relief / 35 psi reset for MLD, TS-LS300, and TS-LS500).*

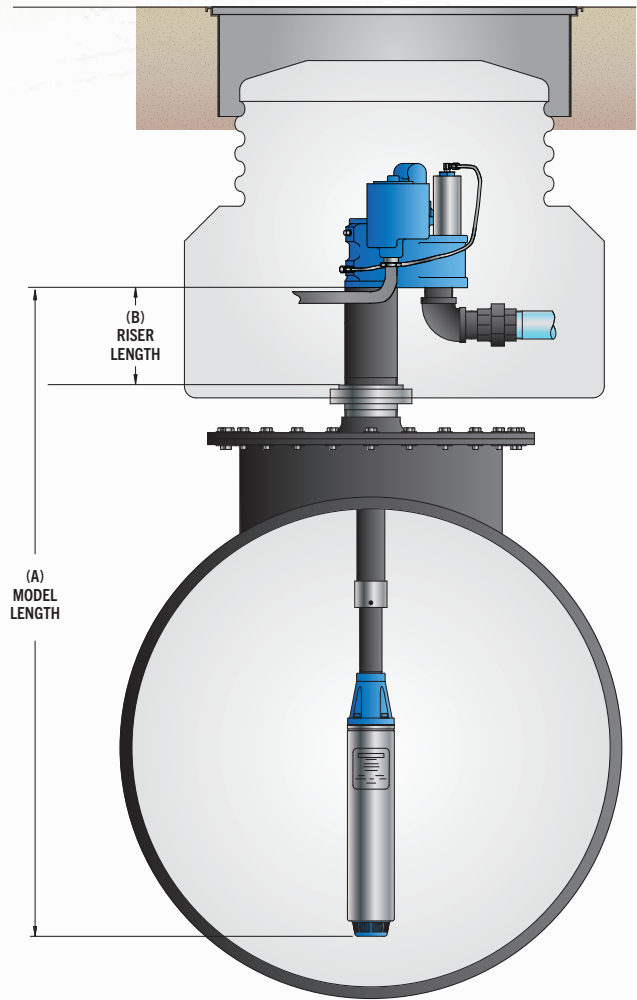

Model Length (A)

| STP Horsepower | Model Length Range | Model Length Designation |
|---------------------|--------------------|--------------------------|
| 1½ Hp | 60" – 88" | VL1 |
| | 91" – 152" | VL2 |
| | 123" – 214" | VL3 |
| 1½ Hp High Pressure | 61" – 89" | VL1 |
| | 92" – 152" | VL2 |
| | 124" – 215" | VL3 |

ORDERING INFORMATION CONTINUED

Standard 1½ Hp Fixed Speed Submersible Turbine Pumps

| Model | Description | Model Length Range Number | Model Length Range* |
|-------------|---------------------------------|---------------------------|---------------------|
| STP150-VL1 | 1½ Hp fixed speed | VL1 | 60" – 88" |
| STP150-VL2 | 1½ Hp fixed speed | VL2 | 91" – 152" |
| STP150-VL3 | 1½ Hp fixed speed | VL3 | 123" – 214" |
| STPH150-VL1 | 1½ Hp high pressure fixed speed | VL1 | 61" – 89" |
| STPH150-VL2 | 1½ Hp high pressure fixed speed | VL2 | 92" – 152" |
| STPH150-VL3 | 1½ Hp high pressure fixed speed | VL3 | 124" – 215" |

Alcohol-Gas (AG) 1½ Hp Fixed Speed Submersible Turbine Pumps

| Model | Description | Model Length Range Number | Model Length Range* |
|---------------|--|---------------------------|---------------------|
| STPAG150-VL1 | 1½ Hp AG fixed speed | VL1 | 60" – 88" |
| STPAG150-VL2 | 1½ Hp AG fixed speed | VL2 | 91" – 152" |
| STPAG150-VL3 | 1½ Hp AG fixed speed | VL3 | 123" – 214" |
| STPAGH150-VL1 | 1½ Hp AG high pressure fixed speed | VL1 | 61" – 89" |
| STPAGH150-VL2 | 1½ Hp AG high pressure fixed speed | VL2 | 92" – 152" |
| STPAGH150-VL3 | 1½ Hp AG high pressure fixed speed | VL3 | 124" – 215" |
| STPAP150-VL1 | 1½ Hp fixed speed with Advanced Protection | VL1 | 60" – 88" |
| STPAP150-VL2 | 1½ Hp fixed speed with Advanced Protection | VL2 | 91" – 152" |
| STPAP150-VL3 | 1½ Hp fixed speed with Advanced Protection | VL3 | 123" – 214" |
| STPAPH150-VL1 | 1½ Hp high pressure fixed speed with Advanced Protection | VL1 | 61" – 89" |
| STPAPH150-VL2 | 1½ Hp high pressure fixed speed with Advanced Protection | VL2 | 92" – 152" |
| STPAPH150-VL3 | 1½ Hp high pressure fixed speed with Advanced Protection | VL3 | 124" – 215" |

Notes:

1. STP models are compatible with fuel mixtures containing up to 10% ethanol with gasoline, up to 5% Biodiesel with diesel fuels, and 20% MTBE, 20% ETBE or 17% TAME with gasoline. STPAG/STPAP models are compatible with fuel mixtures containing diesel fuel with up to 20% Biodiesel, 100% Biodiesel, up to 85% ethanol with gasoline, and 20% MTBE, 20% ETBE or 17% TAME with gasoline.

2. All models are supplied with a standard check valve unless factory option "R" or "W" is specified.

3. All above models require single-phase, 208-230 VAC, 60 Hz incoming power.

4. 4" riser pipe, if supplied locally, must be 4½" OD by ¾" WT tubing.

5. For riser pipe lengths 31" to 60", additional charges apply (call Customer Service for lead times).

*Model length (A) defined as the dimension from turbine manifold bottom to pump motor inlet.

Factory Installed Options

Specified in model number at time of STP order.

| Model | Description |
|-------|--|
| F | Floating suction adapter, 1½" NPT female, must be factory installed |
| K | IFS (intake filter screen) factory assembled to pump motor assembly |
| R | Model R check valve, factory installed, for Veeder-Root® PLLD Line Leak |
| W | Model W check valve, factory installed, for Red Jacket PPM4000 Line Leak |

Field Installed Options

1½ Hp fixed speed specific accessories.

| Model | Description |
|------------|---|
| 400137908 | Syphon check valve, alcohol-gasoline compatible (when ordered with STP) |
| 400818921 | STP-CBS, single-phase control box with lockout switch, 120 Volt coil |
| 402312931 | STP-DHI + SPGC-220 Guardian Series™ Single Phase Smart Controller bundle |
| 402313921 | STP-DHI-CBS, combo DHI with factory-wired STP-CBS |
| 402459931 | Model 65 psi check valve AG compatible, (for secondary of manifolded STPs with Veeder-Root® PLLD) |
| 402507930 | Secondary syphon kit (when two syphon primes are required for one STP) |
| 5800100220 | SPGC-220 Guardian Series™ Single Phase Smart Controller |
| 5800300100 | STP-DHI, dispenser hook isolation for 120 Volt dispenser handle switches, up to eight each |

1/3 & 3/4 HP SUBMERSIBLE TURBINE PUMPS

FE PETRO® 1/3 & 3/4 Hp fixed speed submersible pumps deliver consistent flow rates for low throughput fuels.



HIGHLIGHTS

OPTIONAL FEATURES

Biofuel Blend Compatibility

FE PETRO® pumps are UL listed with both UL79A (up to 85% Ethanol) and UL79B (up to 20% or 100% Biodiesel).

Variable Length

The patented telescoping pump shaft lets installers adjust the length of the pump onsite for the perfect fit.

Advanced Protection

Stop corrosion in its tracks. Special powder-coated, e-coated, and stainless steel components defend your pump in the tank and in the sump from accelerated corrosion.

STANDARD FEATURES

Active Air Eliminator

FE PETRO® STPs come standard with active air elimination, which eliminates air through the highest point in the pump head at all times when the pump is running, assuring air does not pass into discharge piping.

Safety and Ease of Maintenance

FE PETRO® STPs include a contractor electrical disconnect, which requires loosening only one bolt, allowing motor wiring to be disconnected without venting the dangerous tank vapors into the sump when servicing FE PETRO® submersible products.

Simple Servicing

If ever required, the pump can be easily removed from the tank by unthreading three bolts. There is no need to disconnect the syphon system or to remove the leak detector from the system to service the STP.

Turbine Pump Interface

Remote enhanced pump monitoring and control including pump-in-water automation, clogged intake escalation, tank leveling, and tank priority.

Intake Filter Screen

Avoid system damage, pumping slowdowns, and reduce filter changes by keeping harmful tank debris, sediment, and corrosion from entering the pumping system with this factory-installed option.

Manual Pressure Relief

As a standard FE PETRO® feature, a vent screw is provided to bleed line pressure to zero when necessary. By turning this screw, product is diverted back to the tank, dropping line pressure to zero. This reduces fuel discharged into the sump manhole or dispenser pan during servicing, further protecting service technicians and the environment.

Outlast, Outperform with Franklin Electric Inside

FE PETRO® STPs are powered by the legendary Franklin Electric motor and built for long term performance. Franklin Electric-powered submersible pumps provide maximum uptime and a proven track record in the fueling industry that spans more than four decades. They feature best-in-class flow rates and a long history of dependability.

Quality Certification

Franklin Fueling Systems is an ISO 9001 Certified Manufacturer.

SPECIFICATIONS

General

- 1/3 and 3/4 Hp fixed speed models are available in variable length and fixed length options.
- Check valve: 2 3/4" diameter fluorocarbon seal constructed with cast aluminum body and steel backing washer.
- Pressure relief valve: available in four pressure relief settings, integral to check valve. Standard model relieves at 40 psi and resets above 35 psi.
- Syphon: venturi-type syphon primer supplied with every submersible. Syphon check valve and secondary syphon sold separately.
- Air eliminator: every submersible includes a tank return path with one-way check valve to provide active air elimination.
- Electrical disconnect: electrical yoke for positive contractor disconnect during service.

Pump Motor

- 1/3 and 3/4 Hp fixed speed, 3450 rpm, two-stage centrifugal type pump motor with integral, automatic thermal overload protection.
- 1/3 Hp models have a max. pressure of 27 psi.
- 3/4 Hp models have a max. pressure of 30 psi.

Approvals

- cULus listed.
- Consult factory for applicable approvals.

Power Requirements

- 1/3 and 3/4 hp fixed speed models require single-phase, 208-230 VAC, 60 Hz incoming power.
- 1/3 and 3/4 hp fixed speed models incorporate a starting and running capacitor, with internal bleed resistor, rated 370 Volt, 15 microfarad.
- STP-SCI single-phase Smart Controllers and STP-CBS single-phase control boxes are available for 1/3 and 3/4 hp pump control.
- 1/3 hp max. motor draw: 4 Amps.
- 3/4 hp max. motor draw: 7 Amps.

Liquid Compatibility

- Max. liquid viscosity: 70 SSU at 60 °F (15 °C).
- Standard STP models are UL and cUL listed for fuel mixtures containing up to 10% ethanol with gasoline, and 20% MTBE, 20% ETBE or 17% TAME with gasoline.
- STPAG/STPAP (AG compatible) models are UL listed for fuel mixtures containing diesel fuel with up to 20% Biodiesel, 100% Biodiesel, up to 85% ethanol with gasoline, and 20% MTBE, 20% ETBE or 17% TAME with gasoline.
- 1/3 and 3/4 hp fixed speed models can also be used with diesel fuels, fuel oils, kerosene, Avgas, and jet fuels in a non-gelled pourable state.
- All wetted elastomers are made of a high grade, fluorocarbon compound.

1/3 Hp Fixed Speed Pump Performance Chart

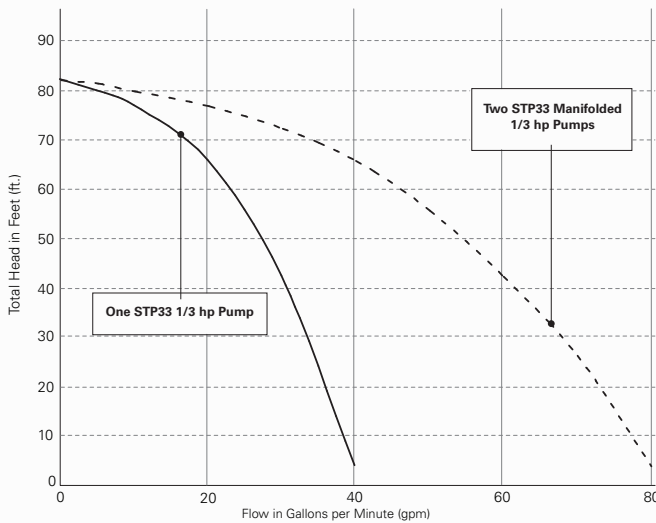

Note: Performance based on pumping gasoline (0.78 specific gravity). Pressure is taken at the manifold discharge outlet. STP33 models are powered by a single-phase, 60 Hz, 208/230 Volt power supply.

3/4 Hp Fixed Speed Pump Performance Chart

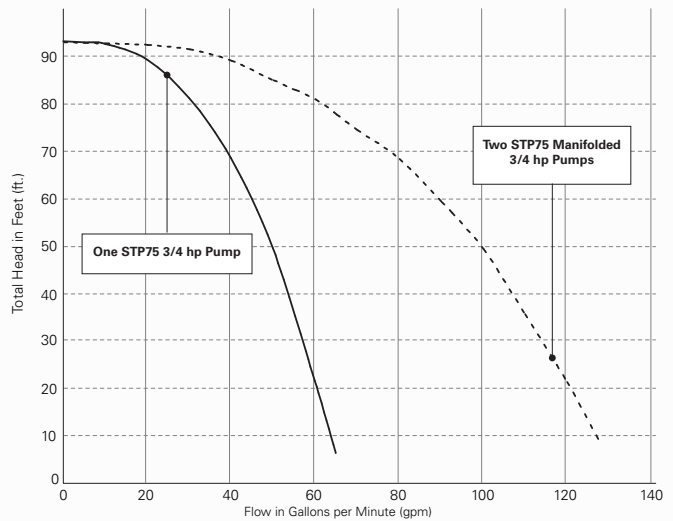

Note: Performance based on pumping gasoline (0.78 specific gravity). Pressure is taken at the manifold discharge outlet. STP75 models are powered by a single-phase, 60 Hz, 208/230 Volt power supply.

ORDERING INFORMATION

1/3 & 3/4 Hp Fixed Speed Submersible Pump Ordering Guide

A typical turbine model designation has up to five components to define the pump being supplied as follows:

STP XXXXX Y - A - B

STP = Basic Model Designation

XXXXX = Factory Installed Options (Model designations may include one or more of the following characters in alphabetical order.)

AP = Advanced Protection with powder-coated, e-coated, and stainless steel components, alcohol-gasoline compatible (up to E85, up to B20, and B100) (Note standard models up to 10% ethanol capable)

AG = Alcohol-gasoline compatible (up to E85, up to B20, and B100) (Note standard models up to 10% ethanol capable)

F = Floating suction adapter (1½" NPT female adapter)

K = Intake filter screen (IFS, factory installed to PMA)

*R = Model R check valve (24 psi relief / 22 psi reset for PLLD)

*W = Model W check valve (16 psi relief / 13 psi reset for PPM4000)

Y = Pump Motor Horsepower Rating

33 = 1/3 Hp fixed speed

75 = 3/4 Hp fixed speed

A = Model Length (see table)

VL1 = Variable length range #1.

VL2 = Variable length range #2.

VL3 = Variable length range #3.

(Note VL2 models fit 94% of all known installations)

B = Riser Pipe Length (see diagram)

Riser pipe length is expressed as two numeric characters that indicate the total length of the riser in inches. Riser pipes are available from 7" to 60" in 1" increments (additional charge for risers 31" or longer).

*Notes: *If not otherwise specified, all STP models are supplied with standard model check valve (40 psi relief / 35 psi reset for MLD, TS-LS300, and TS-LS500).*

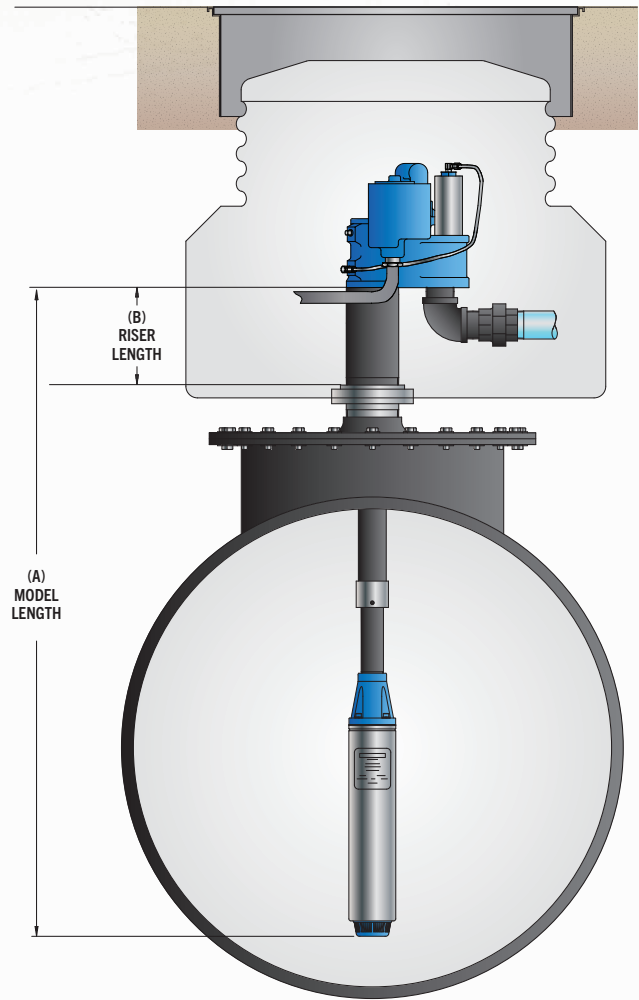

Model Length (A)

| STP Horsepower | Model Length Range | Model Length Designation |
|----------------|--------------------|--------------------------|
| 1/3 Hp | 55" – 83" | VL1 |
| | 86" – 147" | VL2 |
| | 118" – 209" | VL3 |
| 3/4 Hp | 57" – 86" | VL1 |
| | 88" – 149" | VL2 |
| | 120" – 212" | VL3 |

ORDERING INFORMATION CONTINUED

Standard 1/3 and 3/4 Hp Fixed Speed Submersible Turbine Pumps

| Model | Description | Model Length Range Number | Model Length Range* |
|-----------|--------------------|---------------------------|---------------------|
| STP33-VL1 | 1/3 Hp fixed speed | VL1 | 55" – 83" |
| STP33-VL2 | 1/3 Hp fixed speed | VL2 | 86" – 147" |
| STP33-VL3 | 1/3 Hp fixed speed | VL3 | 118" – 209" |
| STP75-VL1 | 3/4 Hp fixed speed | VL1 | 57" – 86" |
| STP75-VL2 | 3/4 Hp fixed speed | VL2 | 88" – 149" |
| STP75-VL3 | 3/4 Hp fixed speed | VL3 | 120" – 212" |

Alcohol-Gas (AG) 1/3 and 3/4 Hp Fixed Speed Submersible Turbine Pumps

| Model | Description | Model Length Range Number | Model Length Range* |
|-------------|---|---------------------------|---------------------|
| STPAG33-VL1 | 1/3 Hp AG fixed speed | VL1 | 55" – 83" |
| STPAG33-VL2 | 1/3 Hp AG fixed speed | VL2 | 86" – 147" |
| STPAG33-VL3 | 1/3 Hp AG fixed speed | VL3 | 118" – 209" |
| STPAG75-VL1 | 3/4 Hp AG fixed speed | VL1 | 57" – 86" |
| STPAG75-VL2 | 3/4 Hp AG fixed speed | VL2 | 88" – 149" |
| STPAG75-VL3 | 3/4 Hp AG fixed speed | VL3 | 120" – 212" |
| STPAP33-VL1 | 1/3 Hp fixed speed with Advanced Protection | VL1 | 55" – 83" |
| STPAP33-VL2 | 1/3 Hp fixed speed with Advanced Protection | VL2 | 86" – 147" |
| STPAP33-VL3 | 1/3 Hp fixed speed with Advanced Protection | VL3 | 118" – 209" |
| STPAP75-VL1 | 3/4 Hp fixed speed with Advanced Protection | VL1 | 57" – 86" |
| STPAP75-VL2 | 3/4 Hp fixed speed with Advanced Protection | VL2 | 88" – 149" |
| STPAP75-VL3 | 3/4 Hp fixed speed with Advanced Protection | VL3 | 120" – 212" |

Notes:

1. STP models are compatible with fuel mixtures containing up to 10% ethanol with gasoline, up to 5% Biodiesel with diesel fuels, and 20% MTBE, 20% ETBE or 17% TAME with gasoline. STPAG/STPAP models are compatible with fuel mixtures containing diesel fuel with up to 20% Biodiesel, 100% Biodiesel, up to 85% ethanol with gasoline, and 20% MTBE, 20% ETBE or 17% TAME with gasoline.

2. All models are supplied with a standard check valve unless factory option "R" or "W" is specified.

3. All above models require single-phase, 208-230 VAC, 60 Hz incoming power.

4. 4" riser pipe, if supplied locally, must be 4 1/2" OD by 3/16" WT tubing.

5. For riser pipe lengths 31" to 60", additional charges apply. (Call Customer Service for lead times.)

*Model length (A) defined as the dimension from turbine manifold bottom to pump motor inlet.

Factory Installed Options

Specified in model number at time of STP order.

| Model | Description |
|-------|--|
| F | Floating suction adapter, 1 1/2" NPT female, must be factory installed |
| K | IFS (intake filter screen) factory assembled to pump motor assembly |
| R | Model R check valve, factory installed, for Veeder-Root® PLLD Line Leak |
| W | Model W check valve, factory installed, for Red Jacket PPM4000 Line Leak |

Field Installed Options

1/3 and 3/4 Hp fixed speed specific accessories.

| Model | Description |
|------------|---|
| 400137908 | Syphon check valve, alcohol-gasoline compatible (when ordered with STP) |
| 400818921 | STP-CBS, single-phase control box with lockout switch, 120 Volt coil |
| 402312931 | STP-DHI + SPGC-220 Guardian Series™ Single Phase Smart Controller bundle |
| 402313921 | STP-DHI-CBS, combo DHI with factory-wired STP-CBS |
| 402459931 | Model 65 psi check valve AG compatible, (for secondary of manifolded STPs with Veeder-Root® PLLD) |
| 402507930 | Secondary syphon kit (when two syphon primes are required for one STP) |
| 5800100220 | SPGC-220 Guardian Series™ Single Phase Smart Controller |
| 5800300100 | STP-DHI, dispenser hook isolation for 120 Volt dispenser handle switches, up to eight each |

FIXED LENGTH SUBMERSIBLE TURBINE PUMPS

FE PETRO® 2 Hp, 1½ Hp, ¾ Hp, and ½ Hp fixed speed submersible pumps are available with fixed lengths.

FIXED LENGTH



SPECIFICATIONS

General

- Check valve: 2¾" diameter fluorocarbon seal constructed on cast aluminum body and aluminum backing washer.
- Pressure relief valve: available in four pressure relief settings, integral to check valve. Standard model relieves at 40 psi and resets above 35 psi.
- Syphon: venturi-type syphon primer supplied with every submersible. Syphon check valve and secondary syphon sold separately.
- Air eliminator: every submersible includes a tank return path with one-way check valve to provide active air elimination.
- Electrical disconnect: electrical yoke for positive contractor disconnect during service.

Pump Motor

- Fixed speed, 3450 rpm, multi-stage centrifugal type pump motor with integral, automatic, thermal overload protection.
- ½ and ¾ Hp fixed speed models are available as two-stage versions.
- 1½ and 2 Hp fixed speed models are available in standard pressure (two-stage) versions and high pressure (H option, three-stage) versions.

Approvals

- cULus listed.
- Consult factory for applicable approvals.
- Franklin Fueling Systems is an ISO 9001 Certified Manufacturer.

Power Requirements

- Fixed length, fixed speed models require single-phase, 208-230 VAC, 60 Hz incoming power.
- Fixed length, fixed speed models are available in ½, ¾, 1½, and 2 Hp versions.
- Fixed length, fixed speed models incorporate a starting and running capacitor with internal bleed resistor.
- A 370 Volt, 15 microfarad rated capacitor is used with ½, ¾, and 1½ Hp fixed length, fixed speed versions.
- A 370 Volt, 40 microfarad rated capacitor is used with 2Hp fixed length, fixed speed versions.
- SPGC-220 Guardian Series™ Single Phase Smart Controller and STP-CBS single-phase control boxes are available for fixed speed pump control.

Liquid Compatibility

- Max. liquid viscosity: 70 SSU at 60 °F (15 °C).
- Fixed length STP models are UL listed for fuel mixtures containing up to 10% ethanol with gasoline, and 20% MTBE, 20% ETBE or 17% TAME with gasoline.
- STPAG/STPAP (AG compatible) models are UL listed for fuel mixtures containing diesel fuel with up to 20% Biodiesel, 100% Biodiesel, up to 85% ethanol with gasoline, and 20% MTBE, 20% ETBE or 17% TAME with gasoline.
- Fixed length models can also be used with diesel fuels, fuel oils, kerosene, Avgas, and jet fuels in a non-gelled pourable state.
- All wetted elastomers are made of a high grade, fluorocarbon compound.

ORDERING INFORMATION

Fixed Length Submersible Pump Ordering Guide

A typical turbine model designation has up to five components to define the pump being supplied as follows:

A typical turbine model designation has up to five components to define the pump being supplied as follows:

STP XXXXX Y - A - B

STP = Basic Model Designation

XXXXX = Factory Installed Options

STP model designations may include one or more of the following characters in alphabetical order:

AG = Alcohol-gasoline compatible (up to E85, up to B20, and B100)

Note: Standard models up to 10% ethanol capable.

F = Floating suction adapter (1½" NPT female adapter)

H = High pressure (1½ hp and 2 hp models only)

K = Intake filter screen (IFS, factory installed to PMA)

M = MagShell® (2 Hp models only)

*R = Model R check valve (24 psi relief / 22 psi reset for PLLD)

*W = Model W check valve (16 psi relief/13 psi reset for PPM4000)

Y = Pump Motor Horsepower Rating

33 = ⅓ Hp fixed speed

75 = ¾ Hp fixed speed

150 = 1½ Hp fixed speed

200 = 2 Hp fixed speed

A = Model Length

Model length is expressed as three numeric characters that indicate the length of the STP from the turbine manifold bottom to the pump motor inlet in inches, available from 37" to 246" (additional charge for models 133" and longer).

B = Riser Pipe Length

Riser pipe length is expressed as two numeric characters that indicate the total length of the riser in inches. Riser pipes are available from 7" to 60" in 1" increments (additional charge for risers 31" or longer).

*Note: If not otherwise specified, all STP models supplied with standard model check valve (40 psi relief / 35 psi reset for MLD, TS-LS300, and TS-LS500).

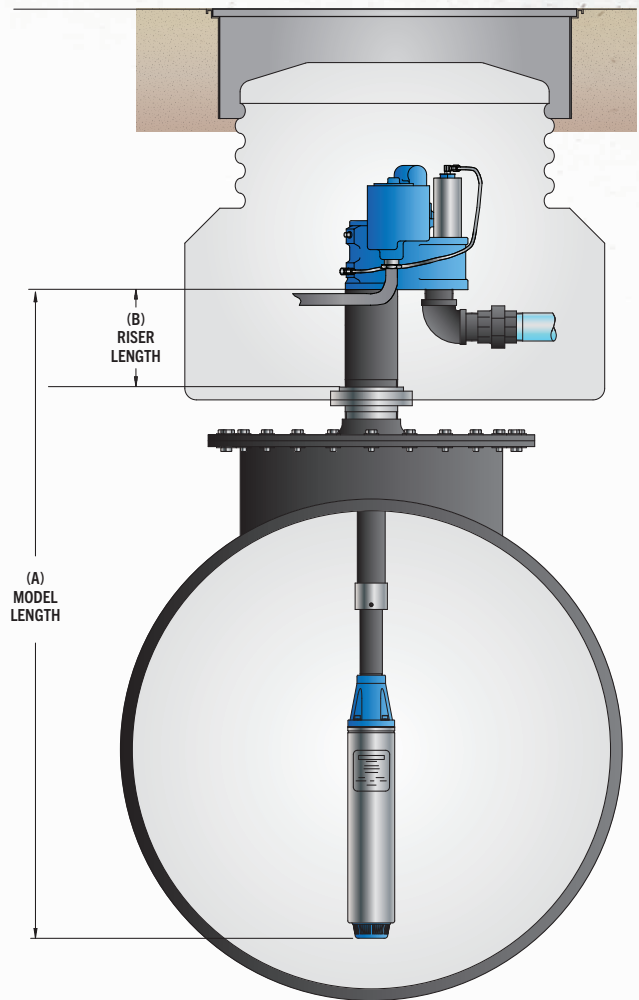

ORDERING INFORMATION CONTINUED

Fixed Length Submersible Turbine Pumps

| Model | Description | Model Length* Range |
|----------|---|---------------------|
| STP33 | 1/3 Hp fixed speed | 37" – 132" |
| STP75 | 3/4 Hp fixed speed | |
| STP150 | 1 1/2 Hp fixed speed | |
| STPH150 | 1 1/2 Hp high pressure fixed speed | |
| STPM200 | 2 Hp fixed speed with MagShell® | |
| STPHM200 | 2 Hp high pressure fixed speed with MagShell® | |

Notes:

1. Remove "M" from model number for non-MagShell® pump motor assembly.
 2. STP models are compatible with fuel mixtures containing up to 10% ethanol with gasoline, up to 5% Biodiesel with diesel fuels, and 20% MTBE, 20% ETBE or 17% TAME with gasoline. STPAG models are compatible with fuel mixtures containing diesel fuel with up to 20% Biodiesel, 100% Biodiesel, up to 85% ethanol with gasoline, and 20% MTBE, 20% ETBE or 17% TAME with gasoline.
 3. All models are supplied with a standard check valve unless factory option "R" or "W" is specified.
 4. All above models require single-phase, 208-230 VAC, 60 Hz incoming power.
 5. 4" riser pipe, if supplied locally, must be 4 1/2" OD by 3/16" WT tubing.
 6. For riser pipe lengths 31" to 60", additional charges apply (call Customer Service for lead times).
- *Model length (A) defined as the dimension from turbine manifold bottom to pump motor inlet. Model length (A) can be a minimum of 37" to a maximum of 211". Adder (p/n 400326912) applies if model length is 133" to 180" (charge is for boards to protect STP shipment). Adder (p/n 400326917) applies if model length is 181" to 211" and (p/n 400389112) applies if model length is 212" to 246" (additional charge is for crating to protect the STP).

Factory Installed Options

| Model | Description |
|-------|---|
| AG | Alcohol-gasoline compatible |
| F | Floating suction adapter, 1 1/2" NPT female, must be factory installed |
| K | IFS (intake filter screen), factory assembled to pump motor assembly |
| R | Model R check valve, factory installed, for Veeder-Root® PLLD Line Leak |
| W | Model W check valve, factory installed, for Red Jacket™ PPM4000 Line Leak |

Field Installed Options

| Model | Description |
|------------|---|
| 400137908 | Syphon check valve, alcohol-gasoline compatible (when ordered with STP) |
| 400818921 | STP-CBS, single-phase control box with lockout switch, 120 Volt coil |
| 402312931 | STP-DHI + SPGC-220 Guardian Series™ Single Phase Smart Controller bundle |
| 402313921 | STP-DHI-CBS, combo DHI with factory-wired STP-CBS |
| 402459931 | Model 65 psi check valve AG compatible, (for secondary of manifolded STPs with Veeder-Root® PLLD) |
| 402507930 | Secondary syphon kit (when two syphon primes are required for one STP) |
| 5800100220 | SPGC-220 Guardian Series™ Single Phase Smart Controller |
| 5800300100 | STP-DHI, dispenser hook isolation for 120 Volt dispenser handle switches, up to eight each |

REPLACEMENT PARTS & ACCESSORIES

The rock solid design of FE PETRO® pumps has remained virtually unchanged since day one, meaning we can, and still do, service our pumps installed since 1988 with backward compatibility.

ORDERING INFORMATION



Replacement Pump Motor Assemblies*

| Model | Description |
|----------|--|
| PMA33 | 1/3 Hp pump motor assembly (16" long) |
| PMA75 | 3/4 Hp 18 1/4" pump motor assembly (18 1/4" long) |
| PMA150 | 1 1/2 Hp pump motor assembly (21" long) |
| PMAH150 | 1 1/2 Hp high pressure pump motor assembly (21 3/4" long) |
| PMA200 | 2 Hp pump motor assembly (23 3/4" long) |
| PMAM200 | 2 Hp pump motor assembly with MagShell® (23 3/4" long) |
| PMAH200 | 2 Hp high pressure pump motor assembly (24 1/2" long) |
| PMAHM200 | 2 Hp high pressure pump motor assembly with MagShell® (24 1/2" long) |



Replacement Gasoline Motor Assemblies*

| Model | Description |
|------------|---|
| PMAAG33 | 1/3 Hp AG pump motor assembly (16" long) |
| PMAAG75 | 3/4 Hp AG pump motor assembly (18 1/4" long) |
| PMAAG150 | 1 1/2 Hp AG pump motor assembly (21" long) |
| PMAAGH150 | 1 1/2 Hp AG high pressure pump motor assembly (21 3/4" long) |
| PMAAG200 | 2 Hp AG pump motor assembly (23 3/4" long) |
| PMAAGM200 | 2 Hp AG high pressure pump motor assembly with MagShell® (23 3/4" long) |
| PMAAGH200 | 2 Hp AG high pressure pump motor assembly (24 1/2" long) |
| PMAAGHM200 | 2 Hp AG high pressure pump motor assembly with MagShell® (24 1/2" long) |



Replacement Variable Speed Pump Motor Assemblies*

| Model | Description |
|-----------|--|
| PMAMVS2 | 2 Hp variable speed pump motor assembly with MagShell® (20" long) |
| PMAAGMVS2 | 2 Hp AG variable speed pump motor assembly with MagShell® (20" long) |
| PMAMVS4 | 4 Hp variable speed pump motor assembly with MagShell® (25" long) |
| PMAAGMVS4 | 4 Hp AG variable speed pump motor assembly with MagShell® (25" long) |



4" STP Extractable Sections (Less Manifold, Riser, and PMA)

| Model | Description |
|--------------|--|
| STPEXT-XXX | Fixed length extractable (XXX indicates model length, p/n 400394901) ** |
| STPAGEXT-XXX | AG Fixed length extractable (XXX indicates Model Length, p/n 400394905) ** |
| STPEXT-VL1 | Variable length #1 extractable (p/n 402074901) |
| STPEXT-VL2 | Variable length #2 extractable (p/n) 402075902) |
| STPEXT-VL3 | Variable length #3 extractable (p/n 402075903) |
| STPAGEXT-VL1 | AG variable length #1 extractable (p/n 402201902) |
| STPAGEXT-VL2 | AG variable length #2 extractable (p/n 402202902) |
| STPAGEXT-VL3 | AG variable length #3 extractable (p/n 402203902) |
| STPAEXT-VL1 | AP variable length #1 extractable (p/n 403614901) *** |
| STPAEXT-VL2 | AP variable length #2 extractable (p/n 403614902) *** |
| STPAEXT-VL3 | AP variable length #3 extractable (p/n 403614903) *** |

Note: Remove "M" from model number for non-MagShell® pump motor assemblies.

* For pump motor assemblies (PMAs) with floating section adapters (1 1/2" NPT female connections), specify "F" in the number; adder charge applies when ordering PMA. For PMAs with intake filter screen, specify "K" in the model number; adder charge applies when ordering PMA.

**Model length (XXX) defined as the dimension from turbine manifold bottom to pump motor inlet. Model length (A) can be a minimum of 37' to a maximum of 211", Fixed Length adders apply for Extractable Model Lengths 133" and longer (please call Customer Service for lead times of Extractables with a model length of 181" and longer).

***Please call Customer Service for lead times of AP Extractables.

ORDERING INFORMATION CONTINUED

PMA, Riser, and Check Valve for Variable Length and Fixed Length Pumps

Use the parts drawing on the following page.

| Item | Model | Description | Qty |
|------|----------------------------|---|-----|
| 1 | 400125001 | 3/16" x 1 5/8" spiral pin | 1 |
| 2 | 400615001 | Manual relief plug (400615002 AG compatible) | 1 |
| 3 | 400211114 | O-ring, MPR plug | 1 |
| 4 | 400627001 | Retaining ring, MPR | 1 |
| 5 | 400616001 | Manual relief screw (400616002 AG Compatible) | 1 |
| 6 | 400333012 | Relief screw, top O-ring | 1 |
| 7 | 400333007 | Relief screw, bottom O-ring | 1 |
| 8 | 400628901 | Manual relief plug assembly, includes items #2 and #3 (400628902 AG compatible) | 1 |
| 9 | 400629901 | Manual relief screw assembly, includes items #4, #5, #6, and #7 (400629902 AG compatible) | 1 |
| 10 | 400259001 | 1/4" NPT pipe plug, may be purchased locally | 3 |
| | 403499001 | 1/4" NPT pipe plug, may be purchased locally (stainless steel, for AP models) | |
| 11 | 400137937 | Syphon check valve | - |
| 12 | 400221930 | Discharge manifold, includes #1, #8, #9, and two #10 | 1 |
| | 400221931 | Discharge manifold (includes item #1, #8, #9, and #10) (for AP models) | - |
| 13 | 151213930 | 156" lead assembly | 1 |
| | 151213932 | 240" lead assembly | |
| 14 | Purchase locally | Stationary vapor tube, 3/8 OD x 7/20 WT | - |
| 15 | 4001689XX (XX = length) | Riser, 4 1/2" OD x 3/16" WT steel tubing (consult factory for lead times for 31"-60" lengths) 7" - 19" 20" - 30" 31" - 49" 50" - 60" | 1 |
| | 4035229XX (XX = length) | Riser, 4 1/2" OD x 4.12" ID (stainless steel, for AP models) consult factory for lead time 7" - 19" 20" - 30" 31" - 49" 50" - 60" | |
| 16 | Purchase locally | 1/2" steel banding (stainless steel for AP models) | - |
| 17 | 400600002 | 5/16-24 x 7/16" set screw for variable lengths only | 3 |
| | 403432002 | 5/16-24 x 7/16" set screw for VL models only (stainless steel, for AP models) | - |
| 18 | 400333015 | Lead assembly O-ring | 4 |
| 19 | 400264009 | 5/16-18 x 1 1/8" socket head cap screw, may be purchased locally | 4 |
| | 403506001 | 5/16-18 x 1 1/8" socket head cap screw, may be purchased locally (stainless steel, for AP models) | |
| 20 | 400263004 | 5/16" high-collar lock washer, may be purchased locally | 1 |
| | 403505001 | 5/16" high-collar lock washer, may be purchased locally (stainless steel, for AP models) | |
| 21 | 403403001 | PMA gasket (403403002 AG/AP compatible) | 1 |
| 22 | PMA XXX | Pump motor assembly, includes item #30 (XXX indicates options and horsepower) | 1 |
| 23 | 400981001 | 3/8-16 x 1" Hex head screw | 2 |
| | 403504001 | 3/8-16 x 1" Hex head screw (stainless steel, for AP models) | |
| 24 | 400285002 | 3/8" standard lock washer, may be purchased locally | 2 |
| | 1117703 | 3/8" standard lock washer (stainless steel, for AP models) | |
| 25 | 400197930 | Manifold assembly cover, includes #10, #26, two #23, and two #24 | 1 |
| | 400197931 | Manifold Assembly Cover (includes item #10, #23, #24, and #26 for AP models) | |
| 26 | 400333238 | O-ring, manifold cover (AG compatible) | 1 |
| 27 | 400147930 | Clamp valve assembly (AG compatible) | 1 |
| 28 | 400174930 | Check valve spring | 1 |
| 29 | 400988931 | Standard check valve, includes item #26 (400988934 AG compatible) | 1 |
| | 400988932 | Model R check valve, (for Veeder-Root™ PLLD) includes item #26 (400988935 AG compatible) | |
| | 400988933 | Model W check valve, (for Red Jacket PPM4000) includes item #26 (400988936 AG compatible) | |
| | 402459931 | Model 65 psi check valve, AG compatible (for secondary manifolded STPs with Veeder-Root™ PLLD) | |
| 30 | 152350902 | PMA hardware pack, includes #21, and four #19 and #20 (152350904 AG compatible) | - |
| -- | 400216905 | AG compatible O-ring kit, includes items #3, #6, #7, and #26 on this page and items #2, #10, #13, #19 and #20 on the Discharge Manifold Assembly page | - |

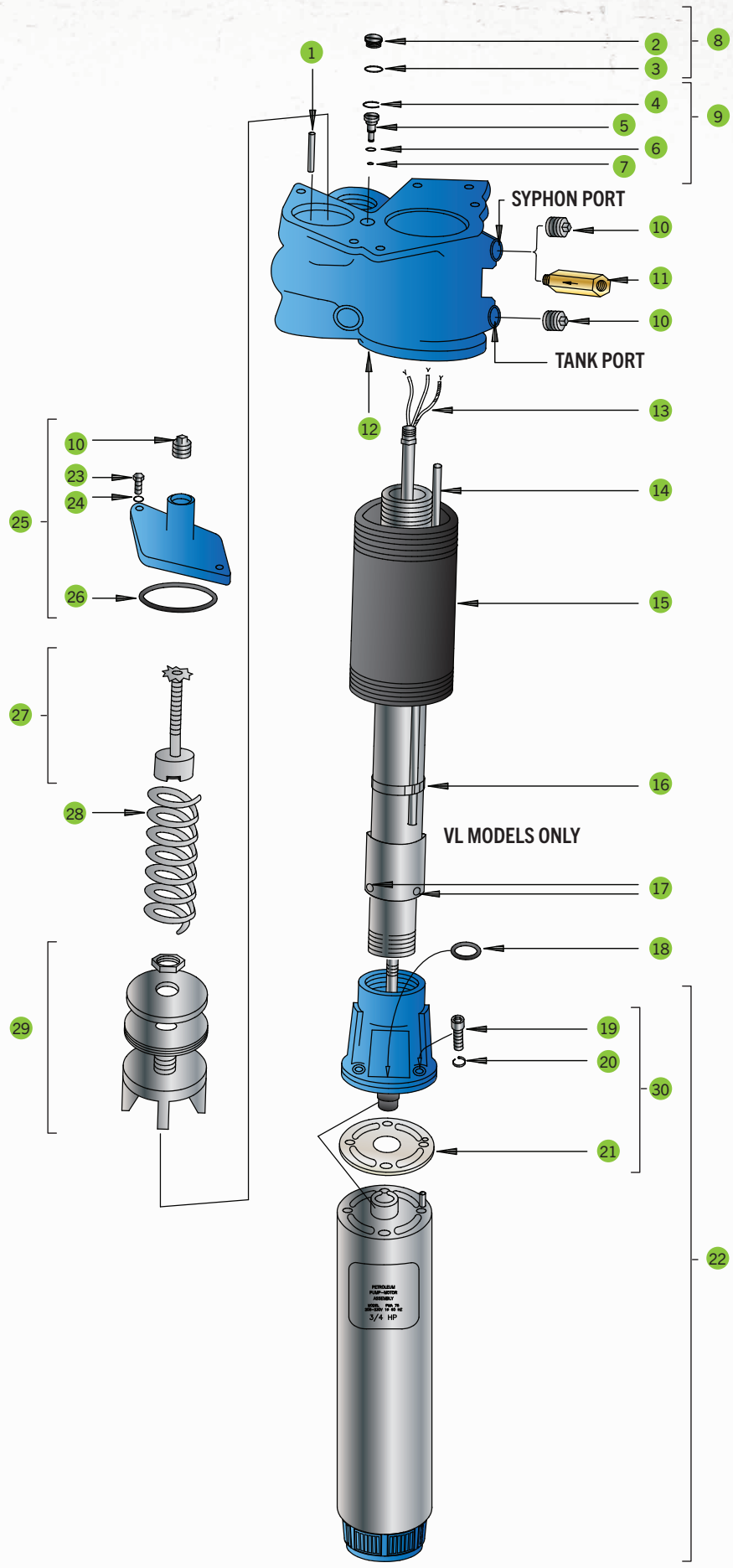

ORDERING INFORMATION CONTINUED

Discharge Manifold Assembly

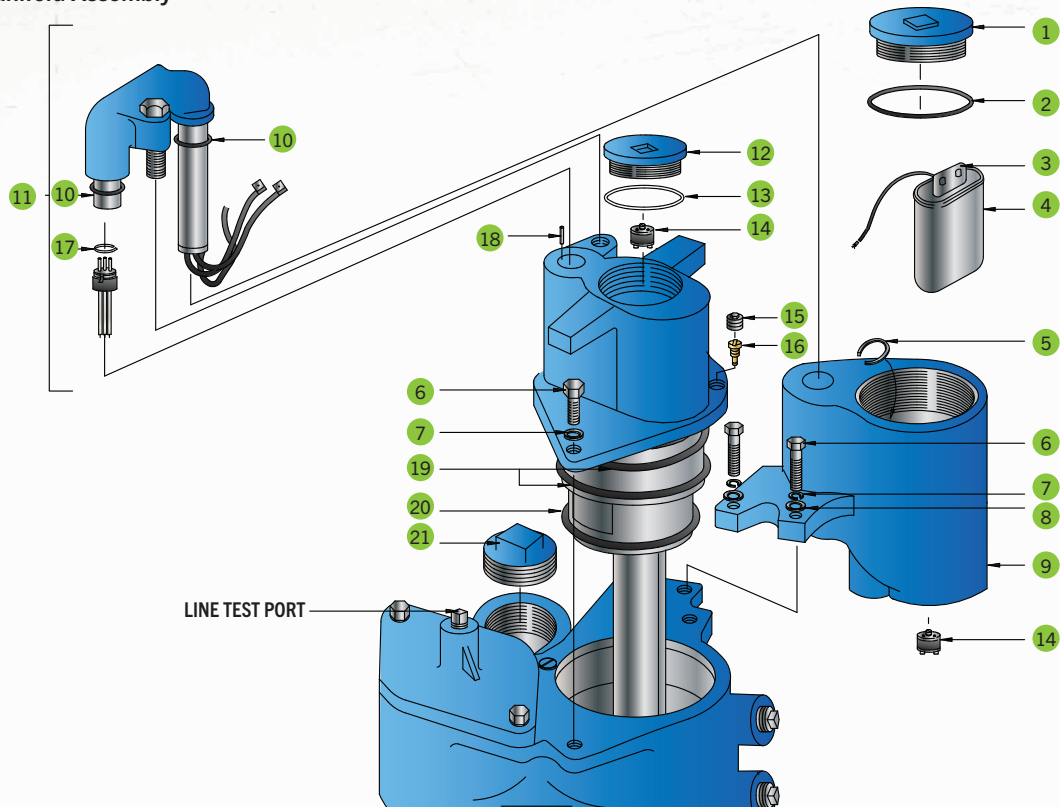

| Item | Model | Description | Qty. |
|------|-----------|--|------|
| 1 | 400192930 | Junction box cover, includes item #2 | 1 |
| | 400192931 | Junction box cover, includes item #2 (for AP models) | |
| 2 | 400210233 | O-ring, junction box cover | 1 |
| 3 | 400655001 | Capacitor boot | 1 |
| 4 | 400170931 | Capacitor assembly for 1/3 to 1/2 hp, 60 Hz, 15µfd, 370 Volt single-phase; includes one black lead | 1 |
| | 400170934 | Capacitor assembly for 2 hp, fixed speed, 60 Hz, 40µfd, 370 Volt single-phase; includes one black lead | |
| 5 | 400257001 | Retaining ring, Female connector | 1 |
| 6 | 400258002 | 3/8-16 x 1 1/4" Hex head bolt, may be purchased locally | 4 |
| | 602011016 | 3/8-16 x 1 1/4" Hex head bolt (stainless steel, for AP models) | |
| 7 | 400285002 | 3/8 standard lock washer, may be purchased locally | 4 |
| | 1117703 | 3/8 standard lock washer (stainless steel, for AP models) | |
| 8 | 400280001 | 3/8 standard flat washer, may be purchased locally | 2 |
| | 403500001 | 3/8 standard flat washer (stainless steel, for AP models) | |
| 9 | 400651930 | Junction box assembly, includes two #6, #7, and #8 | 1 |
| | 400651931 | Junction box assembly (includes item #6, #7, and #8, for AP models) | |
| 10 | 400210212 | O-ring, Female connector | 2 |
| 11 | 400200930 | Wire connector kit, includes male/female connectors, two #10, one #5, and #18 | 1 |
| | 400200931 | Wire connector kit, includes male/female connectors, two #10, one #5, and #18 (for AP models) | |
| 12 | 400589930 | Cover, includes item #13 | 1 |
| -- | 400589931 | Cover, includes item #13 (for AP models) | |
| 13 | 400210229 | O-ring | 1 |
| 14 | 400236903 | Contractor's plug, 4-wire | 2 |
| 15 | 400259002 | 3/8" NPT pipe plug, may be purchased locally (403499002, stainless steel for AP models) | 1 |
| 16 | 400562901 | Syphon jet assembly (400562903 AG compatible) | 1 |
| 17 | 400249001 | Retaining ring | 1 |
| 18 | 400250002 | 1/8" dia. x 1/2" roll pin | 1 |
| 19 | 400333343 | AG compatible O-ring, extractable (upper, large) | 2 |
| 20 | 400333340 | AG compatible O-ring, extractable (lower) | 1 |
| 21 | 400259005 | 2" NPT square head plug | 1 |
| | 403499003 | 2" NPT square head plug (stainless steel, for AP models) | |

ORDERING INFORMATION CONTINUED

Intake Filter Screen

An Intake Filter Screen (IFS) provides fuel filtration for the entire system down to about the size of a grain of sand (0.009" openings). It's designed to keep harmful debris, sediment, and tank corrosion from entering the pumping system and creating service events including dispenser filter changes. Mounts to FE PETRO® or competitive 4" pump motor end bell and only adds about 1" to assembly length.



| Model | Description |
|-----------|--------------------------------------|
| 400660901 | Intake filter screen, single pack |
| 400660912 | Intake filter screen, 12-pack carton |

Check Valves



| Model | Description |
|-----------|--|
| 400988931 | Standard check valve |
| 400988934 | Standard check valve, AG compatible |
| 400988932 | Model R check valve (for Veeder-Root® PLLD) |
| 400988935 | Model R check valve (for Veeder-Root® PLLD), AG compatible |
| 400988933 | Model W check valve (for Red Jacket® PPM4000) |
| 400988936 | Model W check valve (for Red Jacket® PPM4000), AG compatible |
| 402459931 | Model 65 psi check valve (for secondary manifolded STPs with Veeder-Root® PLLD), AG compatible |

Secondary Syphon Kit

For use when two syphon primers are required for one 4" STP. Not available factory installed.



| Model | Description |
|-----------|--|
| 402507930 | Secondary syphon kit (when two syphon primes are required for one STP) |