



Franklin Electric
FUELING SYSTEMS

DIESEL EXHAUST FLUID PUMP MOTOR ASSEMBLIES

FE Petro® brand diesel exhaust fluid (DEF) pump motor assemblies (PMAs) feature a stainless steel close-coupled design that is completely compatible with DEF/AdBlue®. FE Petro® DEF PMAs are powered by the field-proven Franklin Electric motor.

HIGHLIGHTS

- Stainless steel, encapsulated motor ensures longevity and impermeability to DEF seepage.
- Heavy-duty shaft provides superior alignment and resistance to stress.
- Double mechanical shaft seals protect the oil-filled bearing chamber from DEF seepage, assuring minimal wear and proper bearing lubrication.
- Stainless steel hydraulics provide superior performance and efficiency.
- Plug-in type EPDM jacket power cable provides ease of service and DEF compatibility.
- Multiple models available to meet global requirements of voltage and frequency.
- All models are suitable for vertical installation where the pump motor is suspended off the bottom of the tank by the discharge piping.



SPECIFICATIONS

Materials	Stainless steel construction including impellers/diffusers, inlet/outlet, and outer shell
Pump type	5.1" (130 mm) outside diameter centrifugal type pump
Power cable	32.8' (10 m) EPDM jacketed plug-in power cable
60 Hz pump motor	Two-stage pump with 2" NPT female outlet
Motor rating	Continuous operation with motor cooling provided by product flow and protected from dry running
Bypass relief valve	Cracking pressure of 30-40 psi (2.1-2.8 bar) and 4 gpm (15 lpm) minimum flow required at the discharge of all models
Non-return check valve	Maximum cracking pressure of 3 psi (0.2 bar) required between product piping and bypass relief valve of all models
Liquid compatibility	Intended for use with Diesel Exhaust Fluid (DEF) <ul style="list-style-type: none">- DEF is a nonflammable, non-combustible liquid that has a specific gravity of 1.09 at 68°F, and is made per ISO 22241-1 specifications with 32.5% urea and distilled or deionized water.- As defined by ISO 22241-1, DEF is the same as AUS 32® (aqueous urea solution) and also commonly known as AdBlue®.

SPECIFICATIONS CONTINUED

Dimensions

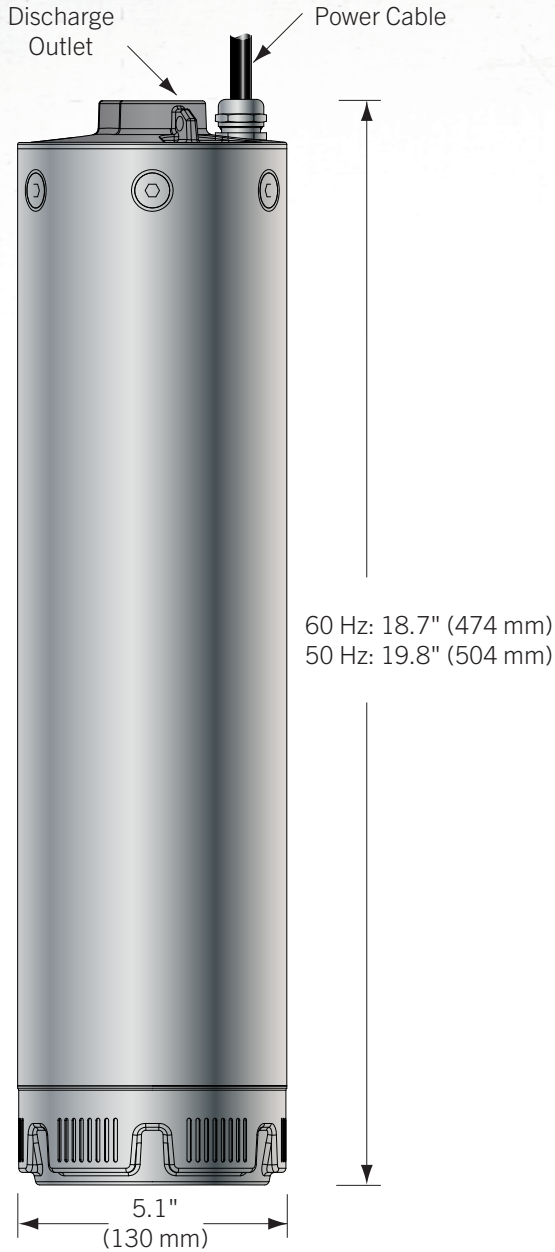

60 Hz DEF Pump Motor Performance

DEF-PMA150A (Single Phase) and DEF-PMA150D (Three Phase)

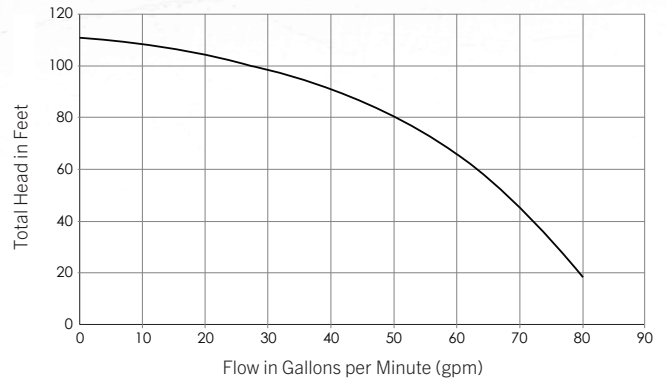

Note: Performance is based on pumping water (1.00 specific gravity). Pressure is taken at the discharge outlet of the pump motor.

ORDERING INFORMATION

Ordering Guide

Complete part numbers have a specific order and are created using the following guidelines:

DEF - PMA YYY Z

DEF = Pump Compatible with DEF

PMA = Pump Motor Assembly

YYY = Pump Motor Hp Rating

150 = 1½ Hp fixed speed (1.1 kW)

Z = Motor Electrical Rating

A = Single phase, 60 Hz, 208-240 VAC (rated 7.9 Amps, requires 25 microfarad run/start capacitor rated 370 VAC)

D = Three phase, 60 Hz, 208-240 VAC (rated 5.0 Amps)

Note: Three phase models require overload protection in motor starter. Single phase models have thermal overload protection built into the motor.

Model	Description
403383903	DEF-PMA 150 A: single-phase, 60 Hz, 208-240 VAC, 1.5 hp (single pack)
403383933	DEF-PMA 150 D: three-phase, 60 Hz, 208-240 VAC, 1.5 hp (single pack)
403383703	DEF-PMA 150 A: single-phase, 60 Hz, 208-240 VAC, 1.5 hp (12 pack pallet)
403383733	DEF-PMA 150 D: three-phase, 60 Hz, 208-240 VAC, 1.5 hp (12 pack pallet)

AdBlue® is a registered trademark of Verband der Automobilindustrie.

AUS 32® is a registered trademark of GBZI Ltd.