

Product Shown
B601-S Cross
Section

SIZES

- Small 25.5"
- Large 41.5"

**See page 2 for dimension drawing and dimension chart*



MATERIAL

- Fiberglass
- Epoxy coated galvanized steel

SPECIFICATIONS

- Water-tight lid prevents leaks
- Quality FRP construction, no need for gelcoat for chemical resistance
- Walk-over diamond plate cover and factory drainage tubes
- Accommodates up to 5 factory installed AST fittings depending on model
- Factory mounting points make a rack system installation simple
- 30-year corrosion warranty
- Doublewall construction can be monitored with vacuum or hydrostatically making it triennial testing exempt with continuous monitoring
- Ships under a continuous 20" Hg vacuum test

About the B600 Series

Bravo's B600 Series singlewall and doublewall transition sumps are compatible with all common motor fuels and can be ordered with standard AST fittings pre-installed. The fittings range from electrical offset (EO) to 3" compression pass-through AST fittings. This series comes standard with positive concrete anchoring and mounting points for optional rack system. Flush-mount diamond plate cover for walkover applications.

Trent Caster
Western Regional Sales Manager
tcaster@sbravo.com
303.359.8862

Bob Hyatt
Eastern Regional Sales Manager
bhyatt@sbravo.com
239.888.6565

AK, AR, AZ, CA, CO, HI, ID, LA,
MS, MT, NM, NV, OK, OR, WEST
TN, TX, UT, WA, WY

AL, CT, FL, GA, IA, IL, IN, KS, KY, MA, ME, MI,
MD, MO, NC, ND, NH, NJ, NY, OH, PA, SD, SC,
EAST TN, VA, VT, WI, WV

TRANSITION SUMPS

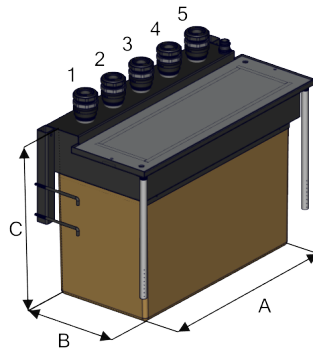
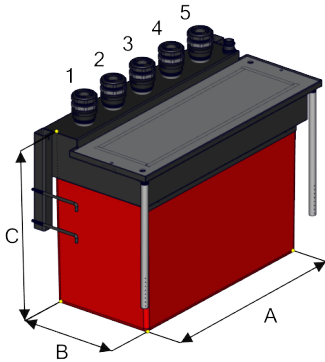

Optional Rack Systems

Part #	Description
RS-501	Small rack for 1, 2 or 3 vents (includes hardware)
RS-502	Large rack for 4 or 5 vents (includes hardware)

B600 Series Walk-over Singlewall

Transition Sump Type	Part #	Description	Fitting size position 1	Fitting size position 2	Fitting size position 3	Fitting size position 4	Fitting size position 5	A	B	C
B600 walk-over flush lid	B601-S	Singlewall FRP vent/transition sump without AST fittings	NA	NA	NA	NA	NA	25.5"	20"	32"
B600 walk-over flush lid	B601-S-200	Singlewall FRP vent/transition sump with 1, 2" AST fitting	2"	NA	NA	NA	NA	25.5"	20"	32"
B600 walk-over flush lid	B601-S-220	Singlewall FRP vent/transition sump with 2, 2" AST fittings	2"	2"	NA	NA	NA	25.5"	20"	32"
B600 walk-over flush lid	B601-S-222	Singlewall FRP vent/transition sump with 3, 2" AST fittings	2"	2"	2"	NA	NA	25.5"	20"	32"
B600 walk-over flush lid	B603-S-22220	Singlewall FRP vent/transition sump with 4, 2" AST fittings	2"	2"	2"	2"	NA	41.5"	20"	32"
B600 walk-over flush lid	B603-S-22222	Singlewall FRP vent/transition sump with 5, 2" AST fittings	2"	2"	2"	2"	2"	41.5"	20"	32"

B600 Series Walk-over Doublewall

Transition Sump Type	Part #	Description	Fitting size position 1	Fitting size position 2	Fitting size position 3	Fitting size position 4	Fitting size position 5	A	B	C
B600 walk-over flush lid	B601-D	Doublewall FRP vent/transition sump without AST fittings	NA	NA	NA	NA	NA	25.5"	20"	32"
B600 walk-over flush lid	B601-D-200	Doublewall FRP vent/transition sump with 1, 2" AST fitting	2"	NA	NA	NA	NA	25.5"	20"	32"
B600 walk-over flush lid	B601-D-220	Doublewall FRP vent/transition sump with 2, 2" AST fittings	2"	2"	NA	NA	NA	25.5"	20"	32"
B600 walk-over flush lid	B601-D-222	Doublewall FRP vent/transition sump with 3, 2" AST fittings	2"	2"	2"	NA	NA	25.5"	20"	32"
B600 walk-over flush lid	B603-D-22220	Doublewall FRP vent/transition sump with 4, 2" AST fittings	2"	2"	2"	2"	NA	41.5"	20"	32"
B600 walk-over flush lid	B603-D-22222	Doublewall FRP vent/transition sump with 5, 2" AST fittings	2"	2"	2"	2"	2"	41.5"	20"	32"