



How to boost your anaerobic digestion ...

Efficient digester heating system with corrugated pipe in Junction City, Oregon

“Due to the excellent handling of the corrugated pipe BIOFLEX valuable installation time and therefore providing significant savings in labor costs. In addition, the quality of the material and the installation without any connections inside the digester provide an absolutely secure and highly efficient operation of the heating system and thus a continuous operation of the biogas plant. This in turn saves the customer time and money.”

Alan Tank, CEO,
Revolution Energy Solutions

The Lochmead Dairy farm in Junction City, Oregon is a modern dairy cattle company, which today covers a large part of its power requirements with renewable energy.



Digesters with BIOFLEX pipe installed at the Lochmead Farm

Since a suitable raw material is close by, in this case cattle manure, biogas can be produced on site to generate electricity that is delivered and sold to the local utility utilizing a proprietary anaerobic digestion process. For this purpose our customer, Revolution Energy Solutions LLC, constructed a biogas plant on the farm property. This plant consists of two digester tanks, an effluent storage tank, and a combined heat and power unit where the fermentation gas is converted into electricity and heat.

For optimum gas production both digesters must be maintained at a constant temperature. To maintain this temperature, external heat is required and is supplied by



Solutions for the Future

the cooling water of the power generator. The decision was made to use a wall mounted pipe heating system. After the evaluation of various pipe systems, the BIOFLEX system by BRUGG PIPESYSTEMS selected for its ease of installation and superior heat transfer capability. The BIOFLEX pipe is a corrugated, flexible pipe made of 316L stainless steel and is made in “endless” lengths. This makes the installation of the pipe considerably faster than any other pipe and eliminates the need for connections inside the digester that may leak down the road. The only connections to the pipe are outside the digester. All of these facts supported the customer’s choice of the BIOFLEX pipe.

Before the actual installation, the BIOFLEX system had to be adapted to the specific design of the digester.

The digesters at this plant are made of glass-fused steel sheets that are bolted together. The supports for the pipe, also made in stainless steel, were designed such that they straddle one sheet height. This way the sheets and the pipe supports could be installed with the same tank bolts.

The BIOFLEX heating system installed inside the digester



Efficient digester heating system with corrugated pipe in Junction City, Oregon

To bring the pipe outside the digester and to terminate it in an end fitting a special penetration fitting was designed. It consists of a flange with a tube that is inserted into a wall penetration, bolted, and sealed to the wall. The pipe is then inserted into the tube and attached to the end fitting with a graphite compression seal to keep the system tight for many years.

The pipe was shipped in individual coils for each heat circuit. This made the installation process quite simple because the pipe could be easily uncoiled and attached to the pipe supports within a few hours per digester.

The installation of the wall penetrations and the connection of the pipe to the end fitting outside the digester completed the installation of an efficient and leak-free system that will provide years of reliable service and improved biogas production.

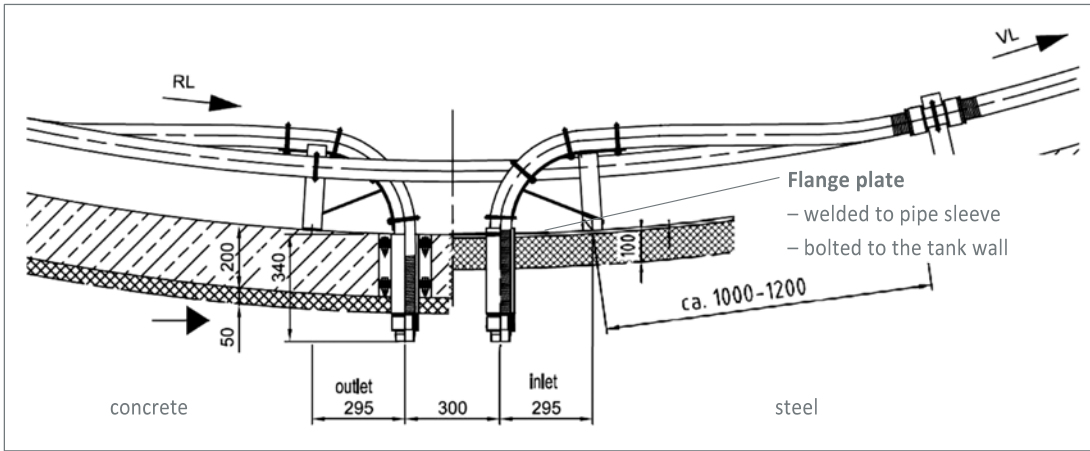

Installation of the BIOFLEX digester heater system – Penetration through concrete or steel digester wall

To obtain additional information please fill in the data below and fax to 706.235.6035

- Please send me additional information
- I have a project and would like to be contacted

Sender

Company: _____

Contact: _____

Tel. No.: _____

Email: _____

Street: _____

City, State, Zip Code: _____

BRUGG Pipesystems, LLC

1801 Parrish Drive
 Rome, GA 30161
 Phone 706.235.5606
 Fax 706.235.6035

kelly.crellin@brugg.com
www.bruggpipe.com



Biogas technology

The effective heating system for biogas-fermenters



Biogas technology

The system package for heating fermentation tanks



NIROFLEX® corrugated piping

NIROFLEX® is a single-walled corrugated piping system made of stainless steel. The key constructional element of these pipes manufactured at our works in long lengths is the helically corrugated pipe.

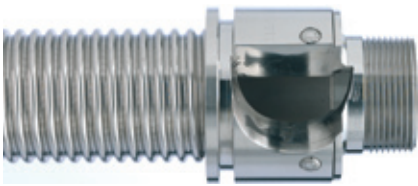

Connector technology

Optimized connections and fittings enable the pipes to be coupled to all standard connections. A flameless graphite packing technology (GRAPA) is used here. This easy-to-fit connector system enables time-savings on installation work without welding.

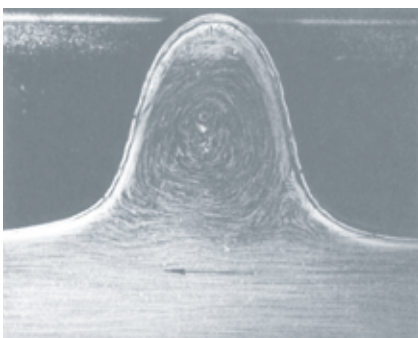

Maximum heat exchange without calcification

Vortices are formed in the helically corrugated pipe. These keep the water in a constant state of turbulence and exchange. The core current is heterodyned by a swirl component formed by the pipe geometry, which creates additional vortices. On the one hand this generates maximum heat exchange while on the other it prevents calcification.

System advantages

- surface up to 50 % higher maximum heat transfer through optimized wall thickness
- pipe profile with optimized thermal and hydrodynamic characteristics
- great flexibility; easily deformable, small bending radii
- can be laid in long lengths
- highly economical with corrosion-resistant materials
- prevention of calcification through turbulent water flow
- quality assurance through helium testing
- "endless manufacture"
- high mechanical load capacity

Biogas technology

Non-weld installation in record time

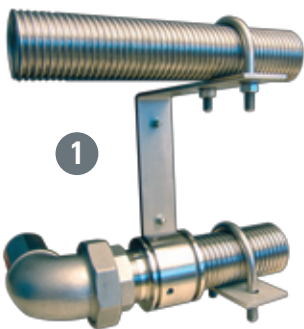

Fermenter equipment with NIROFLEX® corrugated piping

The helically corrugated NIROFLEX® piping is the ideal solution through its simple and non-weld installation.

Other advantages:

- excellent corrosion resistance
- highly flexible and self-compensating
- far higher heat transfer than with conventional piping

Installation

- fast and convenient laying
- simple pipe securing
- non-weld connectors including through-connection through the tank wall

For installation instructions and technical data: see Worksheets Biogas technology BGT.

Biogas technology

System components for the generation and use of regenerative energy

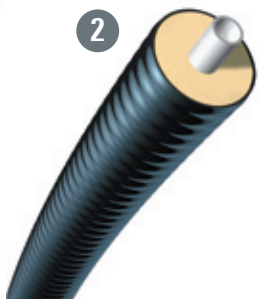
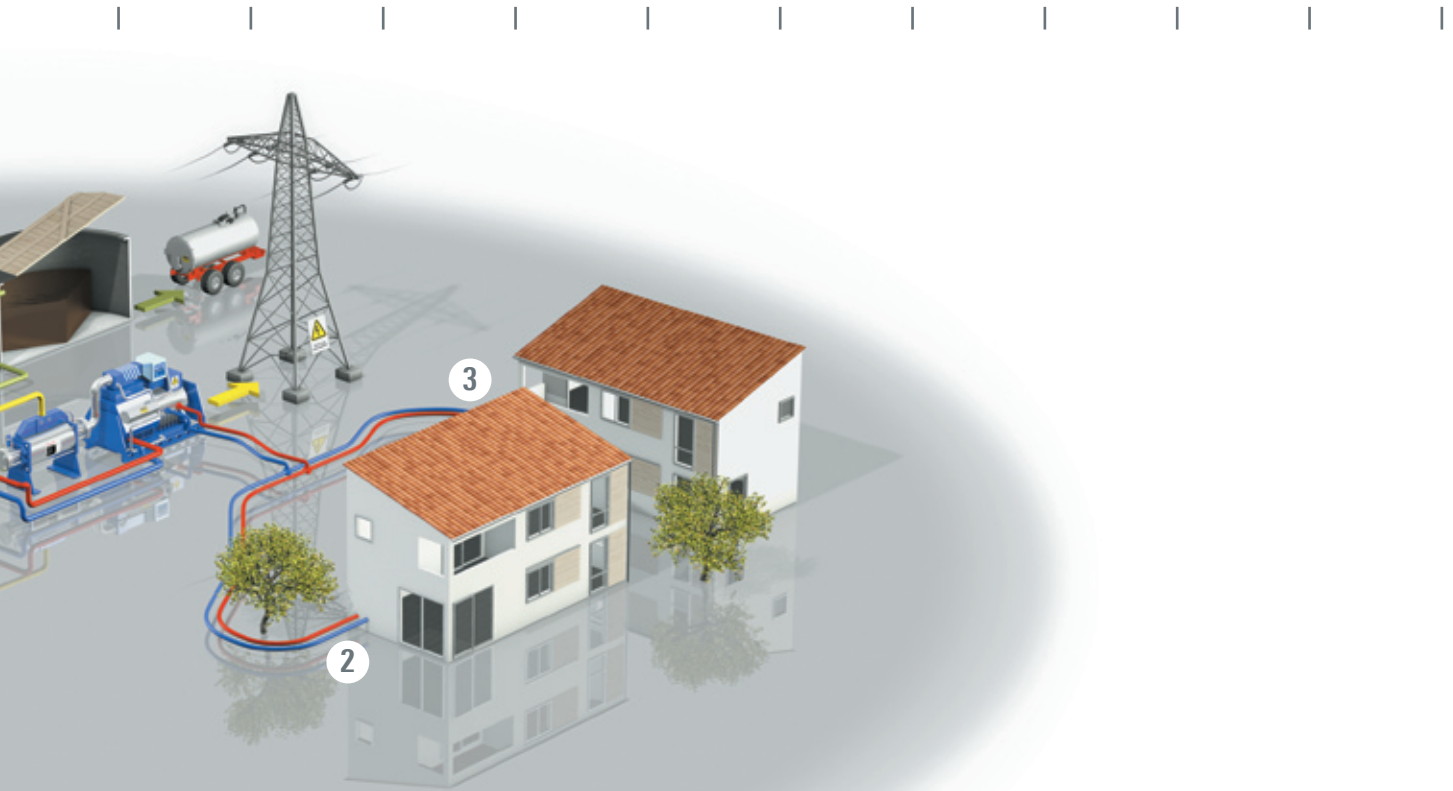

CALPEX® heat-insulated pipe

CALPEX® can be laid direct into the trench with a minimum of work. Connections in the ground can largely be dispensed with. Due to its pre-insulation, the pipe has a high insulation coefficient. The advantage: energy loss is kept to a minimum. The desired length is delivered on site in one piece in a coil. Grouted or screwed connectors.
Dimensions: DN 20 – DN 150

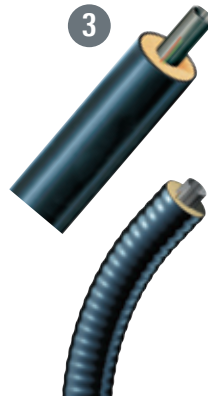

Extensive district heating networks

PREMANT® plastic-sheathed piping is specially designed as a mains pipe for large-scale district heating networks. The properties: high insulation coefficient and leak detection systems.
Dimensions: DN 20 – DN 1000

CASAFLEX® was specially designed for high-temperature applications. Its flexible metallic stainless steel medium pipe allows it to transport media with a temperature of up to 160° C.
Dimensions: DN 20 – DN 100

Biogas technology

Pipe laying - connector technology



System package BRUGG fermenter heating

In order to ensure optimal heat transfer to the substratum, the NIROFLEX CNW 60/66 (DN 50) corrugated pipe is fixed to the wall of the fermentation tank in one or more heating coils.

In addition to the corrugated pipe CNW 60/66, the system package also includes the GRAPA connector system, the necessary wall through-connections including seals and the special brackets for securing the piping to the fermenter wall.

There are two different options for connecting the corrugated pipes to the hot water mains:

Connection inside the fermenter

With the connection inside the tank the corrugated pipe is connected to a rigid pipe by means of the flameless GRAPA graphite connector system. This is then led out of the fermenter through the fermenter wall.

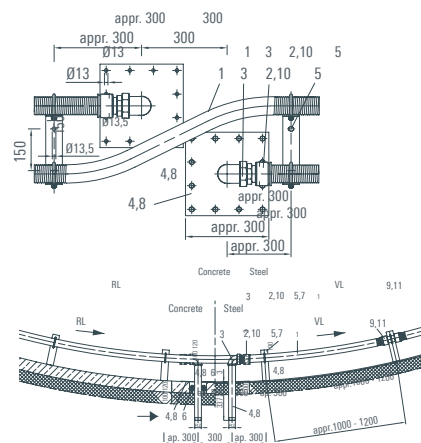

Connection outside the fermenter

In this variant, in order to set up the connection with the corrugated pipe using the flameless GRAPA graphite connector system outside the fermenter, the corrugated pipe is bent through a small bending radius and led through a pipe sleeve which passes through the fermenter wall. This does away with the need for a joint in the fermenter.

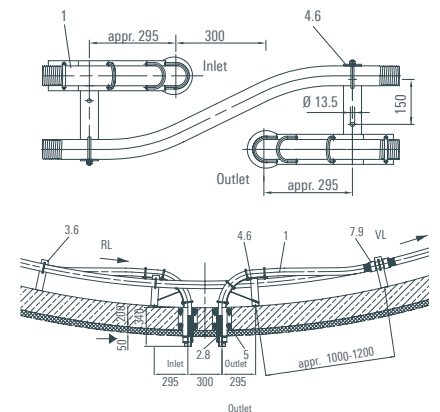

Pipe systems for the future

District heating – Industry – Petrol stations – System packages



Your partner for pipe systems

We are the people you should talk to when you need to find efficient solutions for transporting liquid materials. With our project engineers, development department, in-house production unit, and our professional team of fitters, we have the know-how and the resources to look after your projects competently and reliably in the sectors of heating systems, petrol station construction, industrial plant construction, and system packages.

International network

Our global partnership network can be reached on site at any time. More than 34 partners in 20 different countries will look after you wherever you are.

Customer-specific solutions

Brugg is the full service provider in the field of single-wall, double-wall and insulated pipe systems. This know-how allows us to manufacture project-specific customised items.

Give us a call!

Our engineers would be pleased to advise you and find a made-to-measure solution.

Brugg Rohrsystem AG

Industriestrasse 39
CH-5314 Kleindöttingen
phone +41 (0)56 268 78 78
fax +41 (0)56 268 78 79
pipesystems@brugg.com
www.pipesystems.com

BRUGG Rohrsysteme GmbH

Adolf-Oesterheld-Straße 31
D-31515 Wunstorf
phone +49 (0)50 31 170-0
fax +49 (0)50 31 170-170
info@brugg.de
www.brugg.de

A company of the BRUGG Group