



storage tanks

UL-142 aboveground horizontal

HT-1069

PRODUCT DETAILS

Aboveground storage tanks are engineered to meet the demanding needs of many industries, providing sensible and safe solutions for storing petroleum products and chemicals at bulk plants, transportation facilities, industrial sites, military bases and airports.

Highland Tank uses historically-proven steel design and construction to provide secure, dependable storage tanks.

Tanks are manufactured to UL-142 specifications using flat-flanged heads in single-wall, and double-wall configurations. Constructed of mild carbon steel or stainless steel, they are compatible with the full range of petroleum products including those with higher methanol and ethanol contents.

Standard Construction Features

- » Flat-flanged heads
- » Continuous exterior fillet welds on all joints
- » Custom-located threaded fittings
- » Lifting Lugs
- » UL-142 label
- » 5 psi factory air test/seam inspection
- » Primer coating

Options

Horizontal tanks are available with an array of options that provide solutions for many applications and your specific needs.

Supports, stabilizers, saddles and skids are available for permanent or temporary tank locating.

Dished heads, compartment bulkheads, manways, pump mounts/platforms, and flanged fittings customize the tank to your requirements.

VOC compliant interior and exterior coatings and linings help ensure safe storage of aviation fuels and chemicals. Enamel, epoxy or urethane exterior coatings, and special interior linings are also available.

Any required access or structural steelwork, such as ladders, stairs, platforms or walkways can be supplied. These custom structural accommodations are factory-fitted to facilitate easier field installation.

single-wall or
double-wall

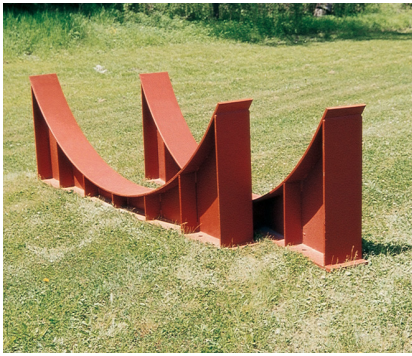

Saddles

Saddles are used to support and maintain the tank's position and provide clearance for visual inspection of the underside. Highland manufactures in accordance with the UL 2-saddle per tank standard which facilitates quicker, more trouble-free installations. Standard saddles provide 6" of clearance and are available up to 12" high.



Supports

Structural Steel Supports are also used to maintain the tank's position and elevation and provide clearance for visual inspection of the tank's underside. Standard supports provide 6" of clearance and are available on horizontal tanks up to 4,000 gallons and 5'4" diameter.



The total square surface area touching the ground is roughly equivalent to that of our skids, which helps minimize the risk of the tank sinking into soft foundations.



Pump Platform shown on large skid tank.

Skids

Skids are used to provide portability for empty horizontal tanks. They stabilize the tank and maintain a fixed elevation if being moved by towing. Skids also provide clearance for visual inspection of the tank underside. Highland manufactures two styles of skids: small tank skids for tanks up to 1,500 gallons with runners fabricated from steel angle and large tank skids with runners made from steel pipe.



Stabilizers

Stabilizers are used to maintain the the tank's position. Our simplest support system available, stabilizers do not provide any clearance for visual inspection of the tank's underside. Standard design consists of two stabilizers welded to the tank and are available on tanks up to 4,000 gallons, 5'4" diameter.



Notes:

Highland recommends that all aboveground horizontal tanks be installed elevated 4-6" to allow for routine visual inspections of the tank's underside.

Do not rely on tack or seal-welded saddles as a means for securing a tank in flood prone areas. A hold down system, connected to an adequately sized anchor pad is recommended.

All Highland UL-142 tanks are supplied with an emergency vent fitting adequately sized to accommodate the intense increase in vapor pressure in the event of fire exposure. Emergency vents are available as an option.

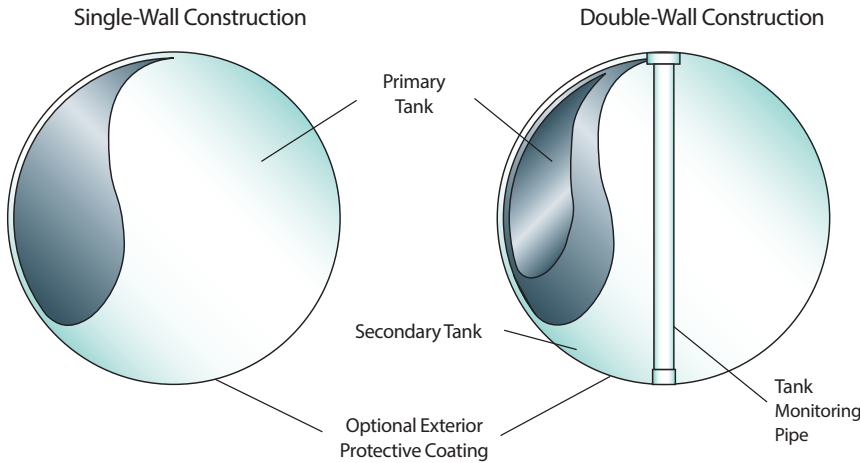

UL-142 Single-wall Construction

Single-wall storage tanks consist of a single sheet of steel meeting ASTM specifications, constructed to UL-142 standards. Material thicknesses range from 12 gauge to 3/8" of mild-carbon or stainless steel. Superior "ribbed" strength is achieved with lap joints employing a minimum 1/2" overlap.

UL-142 Double-wall Construction

Double-wall tanks consist of a primary steel tank wrapped by an exterior steel shell that may be in direct contact with the primary tank creating a full 360° double-wall tank. The interstice can be monitored for an unlikely leak using the 2" monitoring pipe. Both inner and outer tanks are supplied with emergency vent fittings.

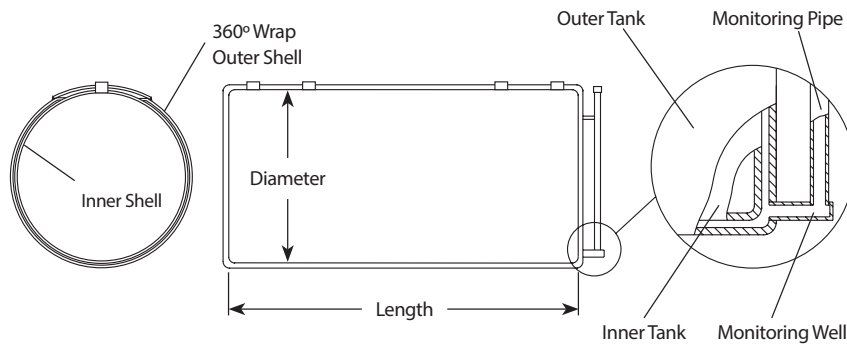

Notes:

For Double-wall Type I tanks, add 6" to length and 1" to diameter for outside dimensions (includes monitoring pipe).

For Double-wall Type II tanks, add 7" to length and 3" to diameter for outside dimensions.

Two-saddle design available for all horizontal tanks. Tank heads may be fabricated with bracing or 1/16" thicker steel, per UL-142.

Consult Highland Tank for NYC Tank sizing as flanged and dished heads will add to length. Custom sizing with a variety of configurations is available upon request.

Volume Gallons	Tank Dimensions	
	Diameter	Length
185	3'-2"	3'-4"
240	3'-2"	4'-0"
300	3'-2"	5'-0"
500	4'-0"	5'-5"
1,000	4'-0"	10'-8"
1,000	5'-4"	6'-0"
1,500	5'-4"	9'-0"
2,000	5'-4"	12'-0"
2,500	5'-4"	15'-0"
3,000	5'-4"	18'-0"
4,000	5'-4"	24'-0"
4,000	6'-0"	19'-0"
4,000	8'-0"	10'-8"
5,000	6'-0"	23'-10"
5,000	8'-0"	13'-4"
6,000	6'-0"	28'-8"
6,000	8'-0"	16'-0"
8,000	10'-0"	14'-0"
8,000	8'-0"	21'-4"
10,000	10'-0"	17'-1"
10,000	8'-0"	26'-8"
12,000	10'-0"	20'-6"
12,000	8'-0"	32'-0"
15,000	10'-0"	25'-6"
15,000	8'-0"	40'-0"
20,000	10'-0"	34'-1"
20,000	10'-6"	31'-0"
25,000	10'-0"	42'-7"
25,000	10'-6"	38'-9"
30,000	10'-0"	51'-2"
30,000	10'-6"	46'-6"
40,000	11'-6"	51'-6"
50,000	12'-0"	59'-2"
50,000	12'-6"	54'-6"
60,000	12'-0"	71'-0"
60,000	12'-6"	65'-5"
60,000	13'-0"	60'-6"
70,000	13'-0"	72'-0"



Stoystown, PA
 One Highland Road
 Stoystown, PA 15563-0338
 814.893.5701

Manheim, PA
 4535 Elizabethtown Road
 Manheim, PA 17545-9410
 717.664.0600

Watervliet, NY
 958 19th Street
 Watervliet, NY 12189-1752
 518.273.0801

Greensboro, NC
 2700 Patterson Street
 Greensboro, NC 27407-2317
 336.218.0801

Friedens, PA
 1510 Stoystown Road
 Friedens, PA 15541-7402
 814.443.6800

Clarkston, MI
 4701 White Lake Road
 Clarkston, MI 48346-2554
 248.625.8700

Mancelona, MI
 9517 Lake Street
 Mancelona, MI 49659-7968
 231.587.8412



PROUDLY MADE IN AMERICA

© Highland Tank - HT-1069 - 01/2019

NOTE: ALL RIGHTS RESERVED. THIS DRAWING MUST NOT BE REPRODUCED IN ANY FORM WITHOUT THE WRITTEN PERMISSION OF HIGHLAND TANK®. HIGHLAND TANK® SHALL BE RESPONSIBLE ONLY FOR ITEMS INDICATED ON THIS FABRICATION DRAWING UNLESS OTHERWISE NOTED. CUSTOMER IS RESPONSIBLE FOR VERIFYING CORRECTNESS OF SIZE AND LOCATION OF FITTINGS, ACCESSORIES, AND COATINGS SHOWN ON THIS DRAWING.

TOUCH UP OF FINISHED PAINT IS REQUIRED BY INSTALLATION CONTRACTOR. TOUCH UP PAINT SHIPPED WITH TANK.

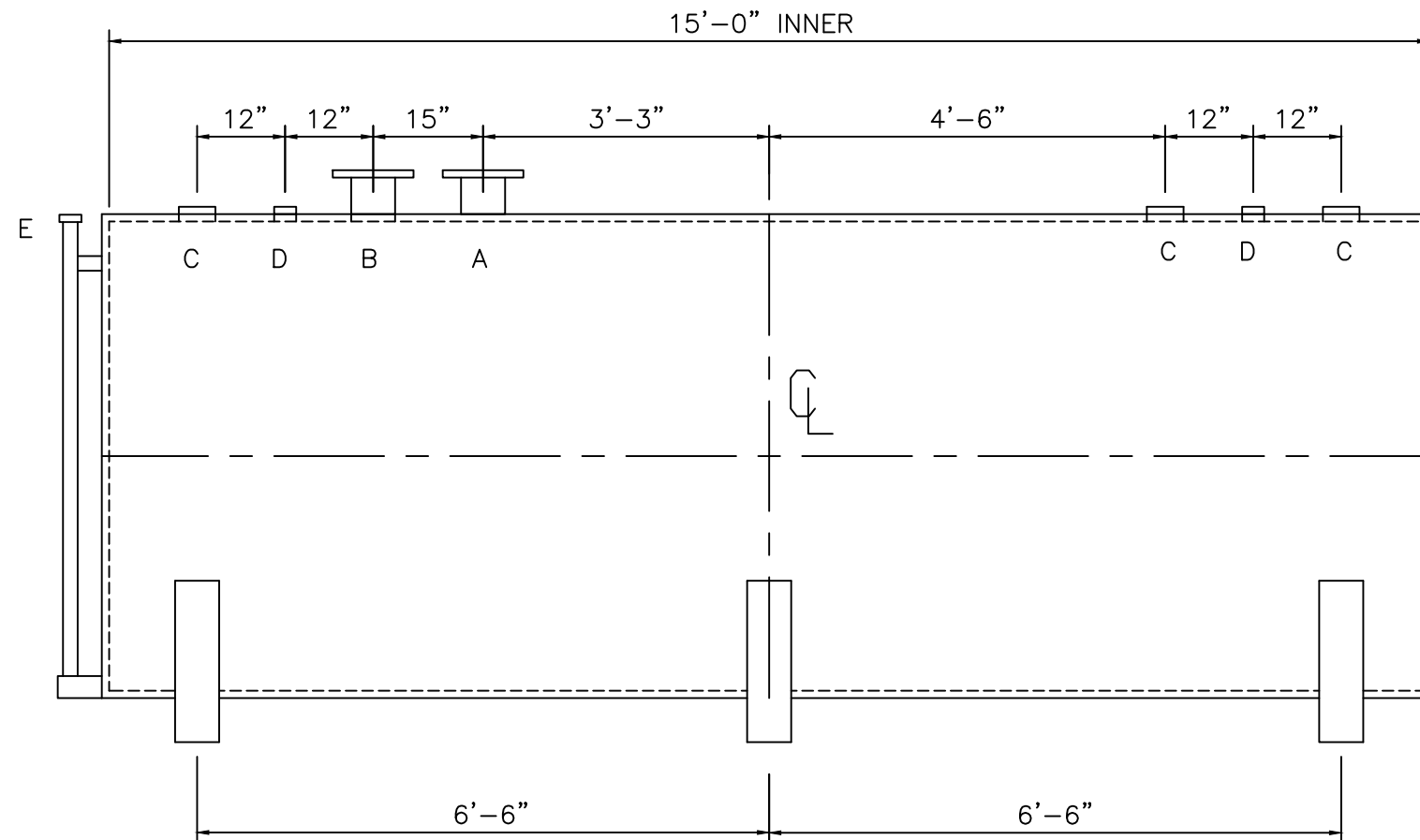
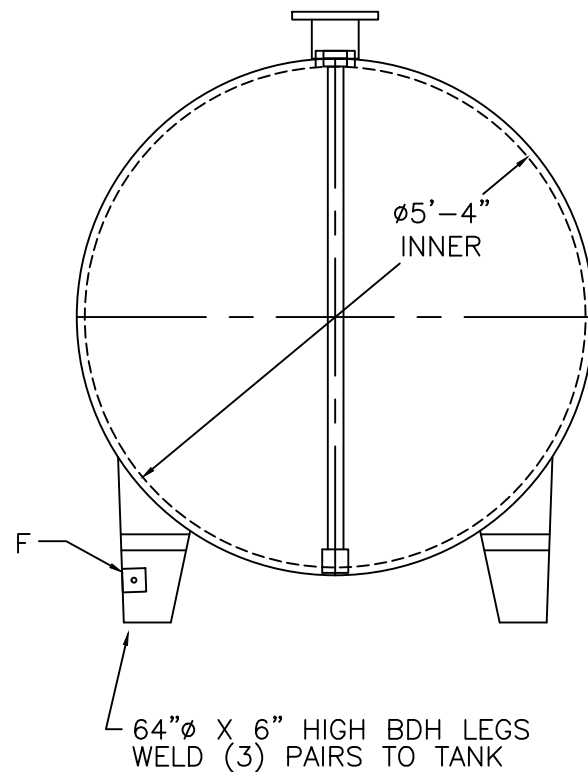

DESIGN DATA	
CAPACITY - 2,500 GALLONS	
TYPE - DOUBLE WALL - TYPE I	
NO. REQ. - -	
OPERATING PRESSURE - ATMOSPHERIC	
SPECIFIC GRAVITY = 1.0	
TANK MATERIAL - MILD CARBON STEEL	
THICKNESS - INNER- HEADS: 7 GA SHELL: 7 GA	
THICKNESS - OUTER- HEADS: 10 GA SHELL: 10 GA	
CONSTRUCTION - INNER - LAP WELD OUTSIDE ONLY	
OUTER - LAP WELD OUTSIDE ONLY	
TANK TEST - INNER - 5 PSIG	
OUTER - +3 PSIG OR 13"hg VACUUM	
INT. FINISH - NONE	
-	
EXT. FINISH - SHOP PRIMER	
-	
LABEL - UL 142	

LEGEND	
A	6" FFSO 150# FLANGE THROUGH OUTER SHELL ONLY, MARK WITH SPECIAL WARNING LABEL - INTERSTITIAL EMERGENCY VENT USE ONLY
B	6" FFSO 150# FLANGE - PRIMARY EMERGENCY VENT USE ONLY
C	4" FITTING
D	2" FITTING
E	2" INTERSTITIAL MONITOR PIPE
F	3" x 3" PLATE w/ 1/2"Ø (MIN.) HOLE ON CENTER (GROUNDING LUG- ONE REQ'D)

 Highland Tank	
UNLESS NOTED, TOLERANCES ARE +/- 1"	
2,500 GAL 64"Ø DW BDH TANK	
CUSTOMER:	
PROJECT:	
QUOTE NO:	CHK'D BY:
SCALE: 1/2" = 12"	DATE:
DWG. BY:	DWG. NO: 02500BDH64DW