

PIUSI
®



MADE FOR USA



 **B.SMART**

ETL RANGE - USA & CANADA

**SIMPLE, INTUITIVE, SMART
FUEL MANAGEMENT SYSTEM
SPECIFICALLY ENGINEERED FOR THE USA**



BE SMART
AND ENTER
THE NEW
ERA OF FLEET
MANAGEMENT!



PIUSI B.SMART:

piusi.com/usa



NEW FUEL MANAGEMENT SYSTEM

PIUSI B.SMART:
the name speaks for itself!
An intuitive and simple Fuel
Management System!

B.SMART is composed of
hardware **MCBOX B.SMART** and
software (APP for drivers and
a web APP on Cloud for fleet
managers) driven by **Bluetooth**
technology to easily monitor
and manage any fleet; from the
smallest to the largest.

Made in Italy by the top-quality
Italian manufacturer, **PIUSI**,
but specifically engineered
for the USA, B.SMART has an
innovative core providing users
and managers with a streamlined
and easy-to-use experience.

Are you ready for
the future?



WHY CHOOSE THE PIUSI FMS?

While the FMS market is full of many solutions, **PIUSI B.SMART** stands out for its distinctive characteristics:

- **Simple:** you just need a smartphone and Bluetooth to make it work;
- **Cloud-based:** no local network required;
- **APP-based:** it works with an intuitive and simple APP;
- **Expandable:** the same software fits any fleet size;
- **Multi-customer/multi-site management:** manage control units located in different geographical locations thanks to its Cloud-based system;
- **Two-hose FMS;**
- **Remote access app-based with NO FEES:** no rental or recurring fees;
- **Key-pad in case of no smart-device availability.**

PIUSI B.SMART is a unique all-in-one FMS: the MCBOX hardware, as well as the B.SMART software and all the pumping system components (sold separately) are all made in house by the same Italian manufacturer, PIUSI. The only Company in the market!



PIUSI B.SMART: MONITOR & MANAGE YOUR FUELING TRANSACTIONS



1

MANAGE THE SITE

Set, activate and monitor your site.

2

CHECK FILL-UPS

Check all fuel transactions at a glance.

3

REAL TIME

Receive all information from the site immediately*



* Real time as long as B.Smart Smart phone APP is connected to the internet. Otherwise, data will be transferred once B.Smart Smart phone APP connects to the internet (Wi-Fi or mobile network).

ONE SOFTWARE, MULTIPLE CONTROL UNITS SUITABLE FOR ANY FLEET SIZE

piusi.com/usa

→ EXAMPLE A Single-site installation with one hose

PIUSI B.SMART is a uniquely expandable system: the software is always included “in the box” and is suitable for any fleet size: from the smallest to the largest, single and multi-site.

As the PIUSI B.SMART software is **Cloud based**, it doesn't require any installation on a local PC to allow fleet managers to **check the site from anywhere** and monitor fuel transactions.

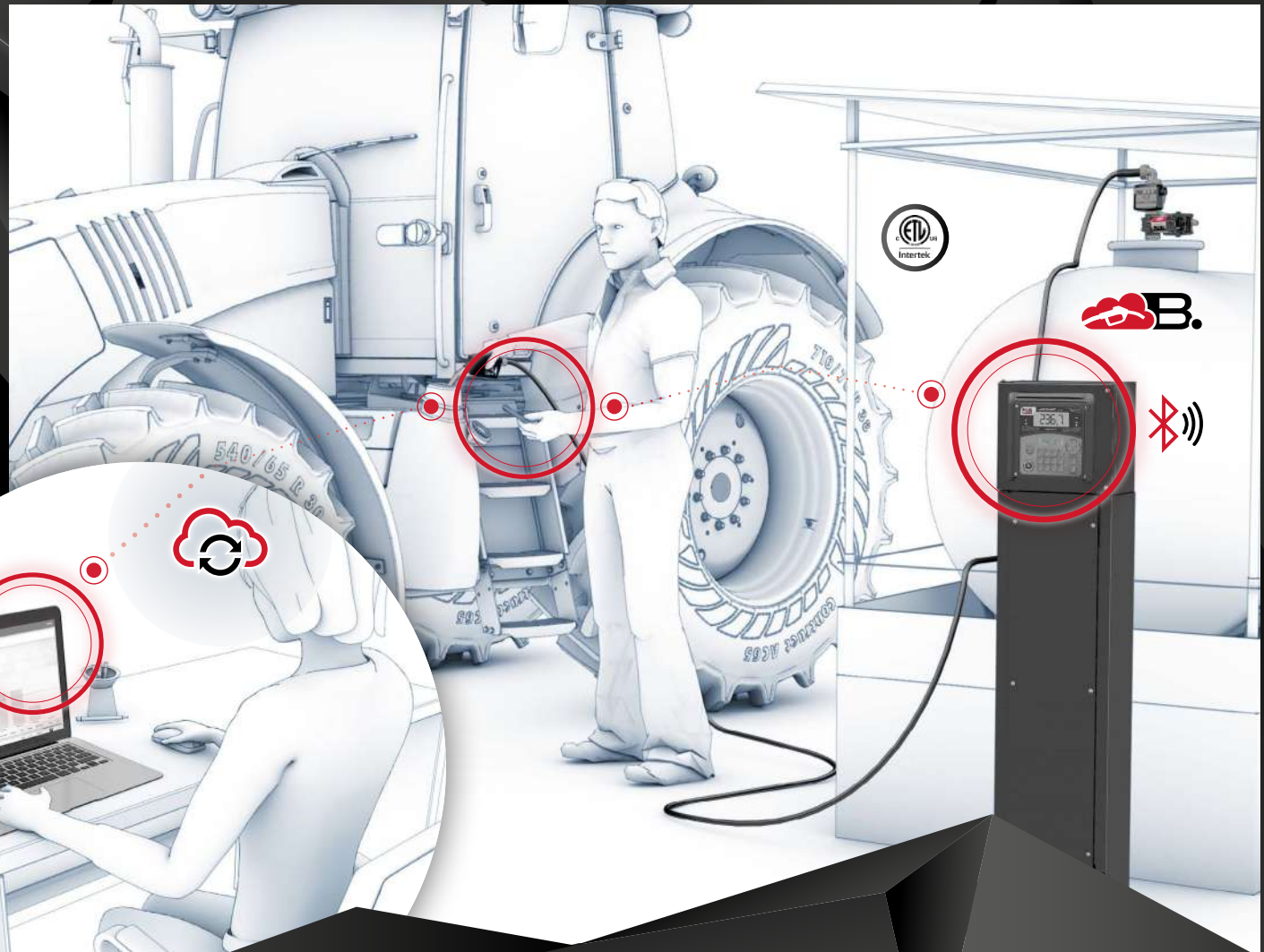

→ **EXAMPLE B** Single-site installation with two hoses

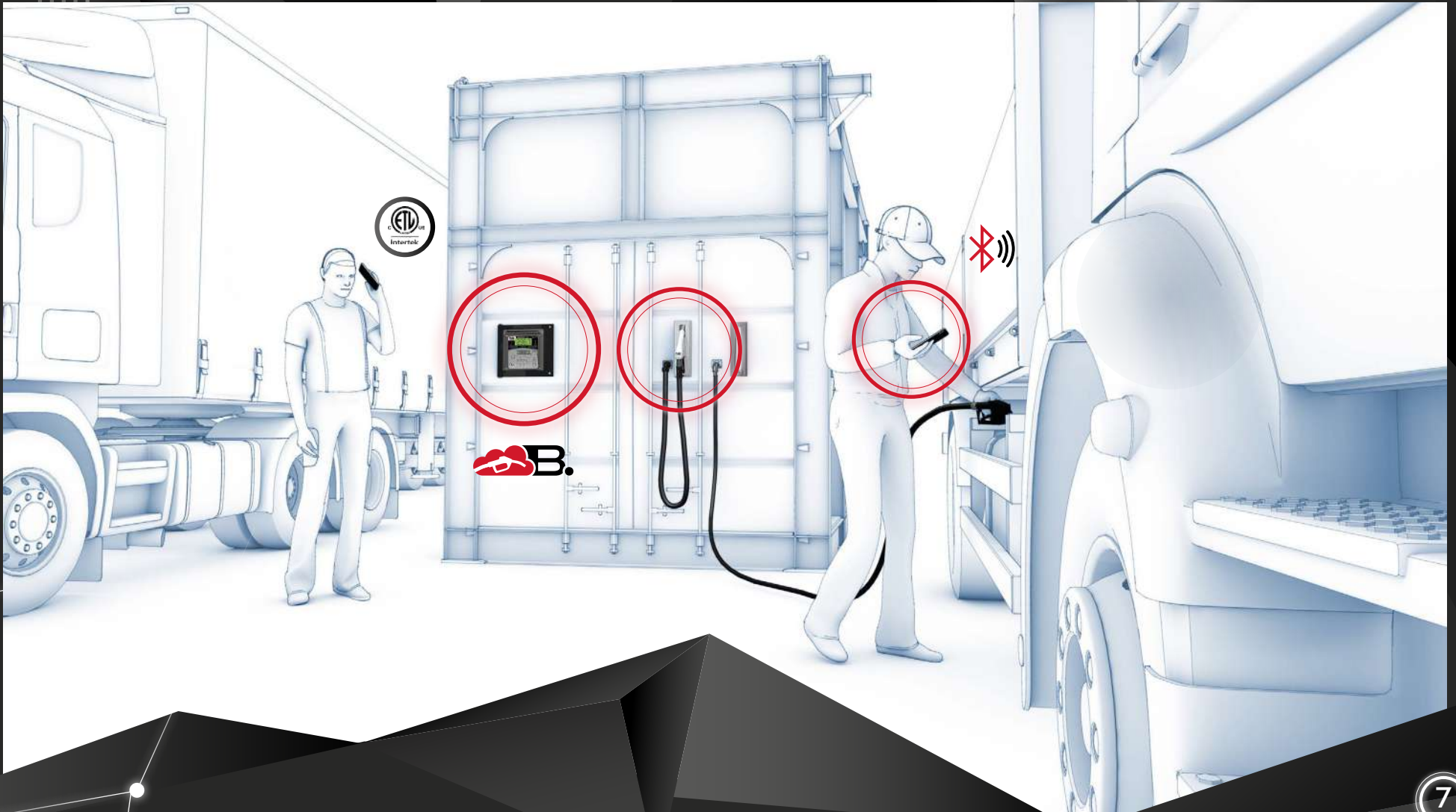

PIUSI B.SMART AS SIMPLE AS A CLICK

piusi.com

1 FILL IN THE INFORMATION

The APP for drivers just requires a smart device with Bluetooth to work properly: **once the APP is open, the smart device immediately connects to the MCBOX B.SMART to start the refueling operation.**

DISPENSER

Choose the dispenser

1

VEHICLE

Choose the vehicle or insert the registration number

2

ODOMETER

Insert the mileage

3

2

REFUELING

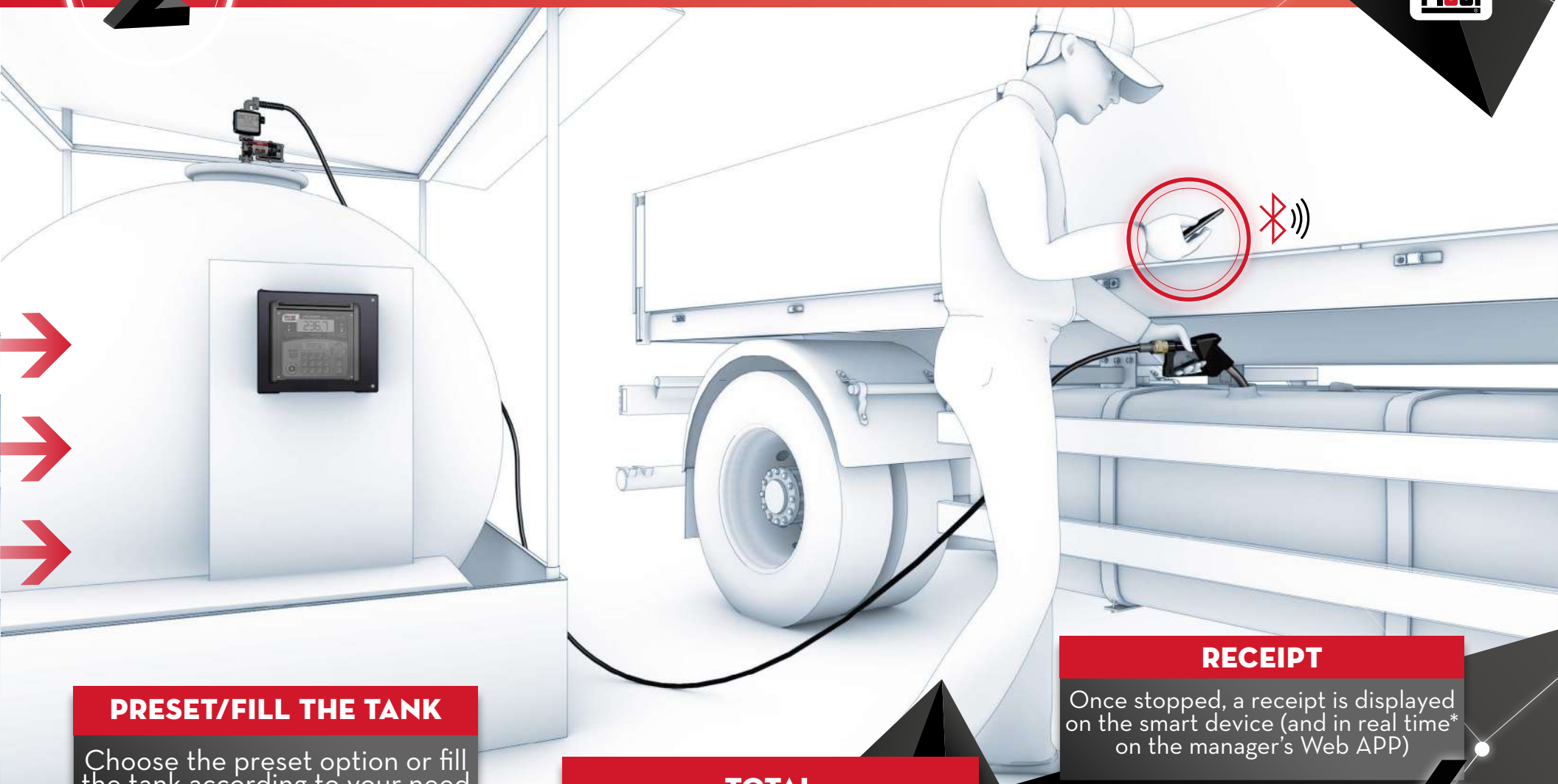

PRESET/FILL THE TANK

Choose the preset option or fill the tank according to your need

4

TOTAL

Check the ongoing transaction on your device or on the control unit's display

5

RECEIPT

Once stopped, a receipt is displayed on the smart device (and in real time* on the manager's Web APP)

6

* Real time as long as B.Smart Smart phone APP is connected to the internet. Otherwise, data will be transferred once B. Smart Smart phone APP connects to the internet (Wi-Fi or mobile network).

PIUSI B.SMART: ADVANTAGES FOR DRIVERS

piusi.com/usa

PIUSI B.SMART is specifically developed to **support and simplify all refueling operations** both on the drivers' and on the manager's side:

- It requires only a **smart device** to work; **driver key or PIN is not required**
- It works with all **iOS** and **Android** mobile devices
- The B.SMART APP is available both on **APPLESTORE** or **PLAYSTORE** simple to find and free to download
- As the APP is connected via **Bluetooth** and it works even if no network is available*
- If needed, the system can also work with the **optional driver key or user PIN**

Available on:



IT CAN BE USED ALSO WITH A REMOTE FIXED TABLET** INSTALLATION



key-pad in case of no smart-device availability

* Transactions will be transferred once the network is available again.

**Not provided

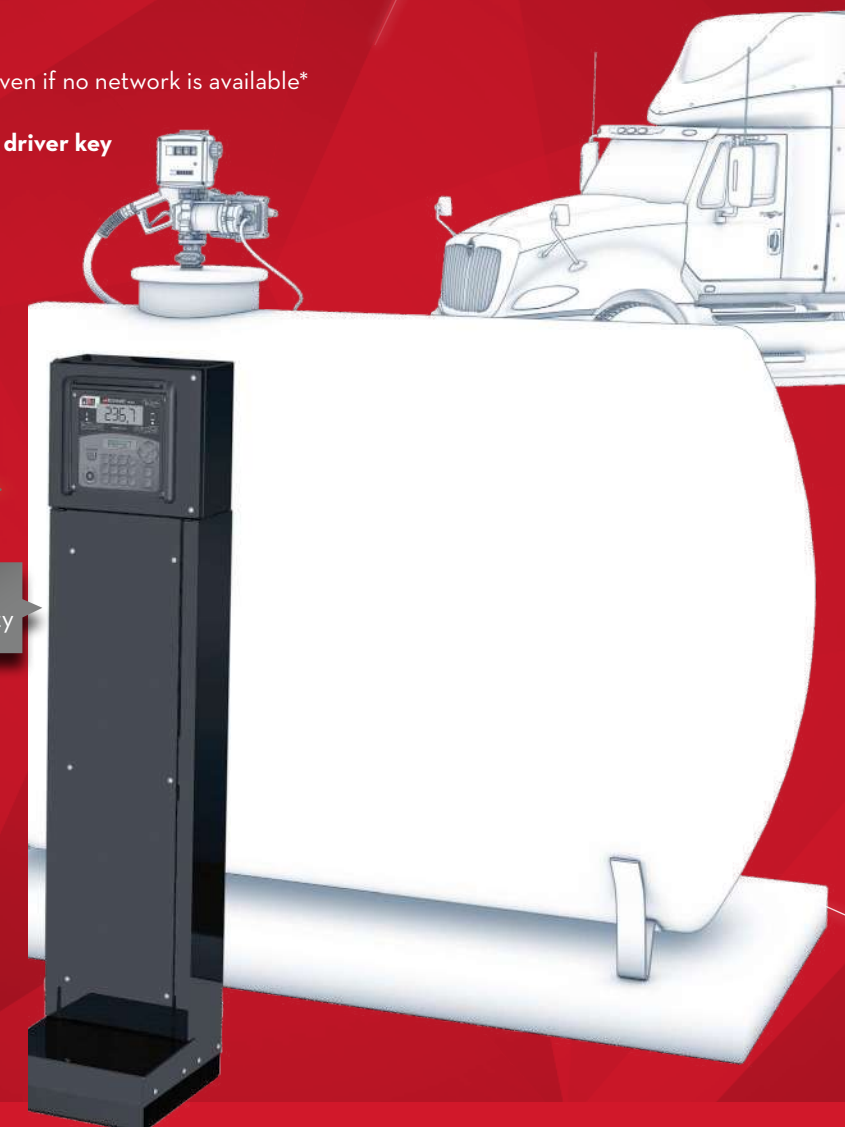

PIUSI B.SMART:

ADVANTAGES FOR MANAGERS



➔ PIUSI B.SMART is a Fuel Management System that takes advantage of **Cloud technology** software to control and manage the fleet:

- **No software installation** required (Cloud based)
- Quick and easy to use; Saving time and money
- **Expandable** and suitable for any fleet size; utilizing the same software (no upgrade required)
- **Real time** feedback from the site*

API

Connect your ERP to B.SMART with the integrated API interface.

*Real time as long as B.Smart Smart phone APP is connected to the internet. Otherwise, data will be transferred one B.Smart Smart phone APP connects to the internet (Wi-Fi or mobile network).



MANAGE THE SITE:

piusi.com/usa

SET, ACTIVATE AND MONITOR YOUR SITE

CONFIGURE

Create your site, set up dispensers and enable drivers.

MANAGE

Add or delete sites, dispensers and users.

CHECK

All information is under control.

➔ PIUSI B.SMART allows you to enter all the parameters useful to **manage the site properly**: locations, fuel dispenser names, drivers, vehicle categories and vehicles:

- Easy installation procedure
- Unique code to identify each site
- Detailed icons help to easily identify dispensers for a complete overview of installed devices
- Avatar of all drivers



CHECK REFUELING TRANSACTIONS: ALL TRANSACTIONS AT A GLANCE



PIUSI B.SMART allows you to **keep track of all the transactions** and refueling operations made. A user-friendly interface helps **gather** and **filter** information to get real control at a glance:

- **Check** and **control** transactions
- **Receive** and download the related receipts
- **Export** data to .pdf or .xlsx

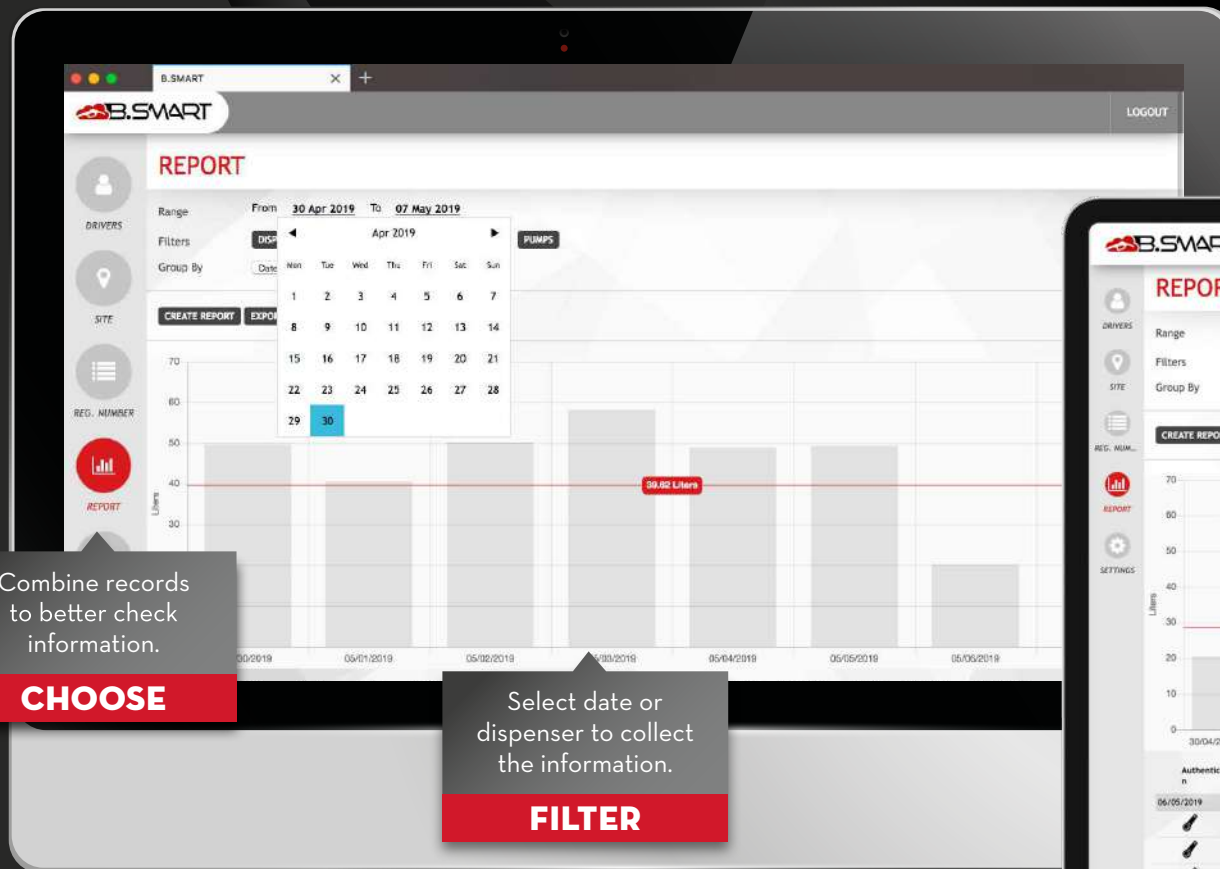

Combine records to better check information.

CHOOSE

Select date or dispenser to collect the information.

FILTER

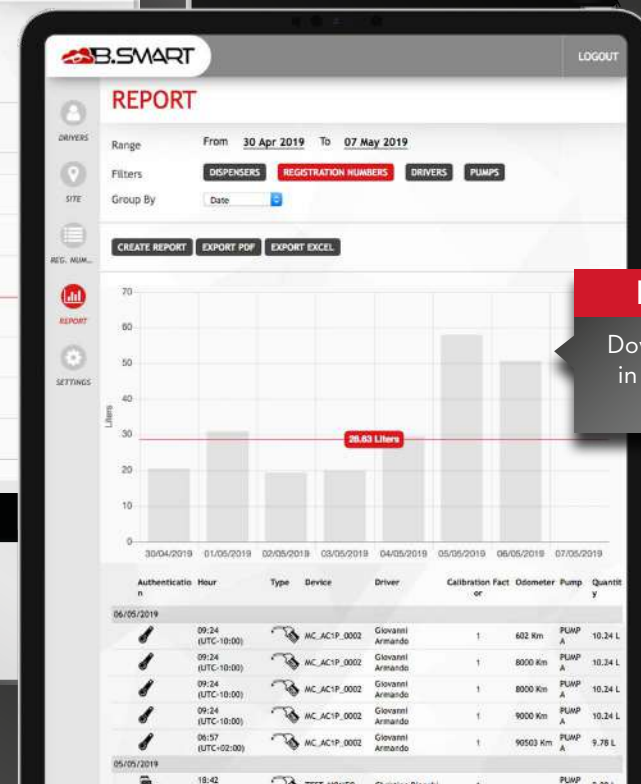

EXPORT

Download all data in the preferred file format.

REAL TIME:

IMMEDIATELY RECEIVE ALL FEEDBACK FROM THE SITE

➔ One of the main features of PIUSI B.SMART is the **real time function** that allows you to keep track of all the transactions immediately*:



DRIVER
Mobile APP
B.SMART

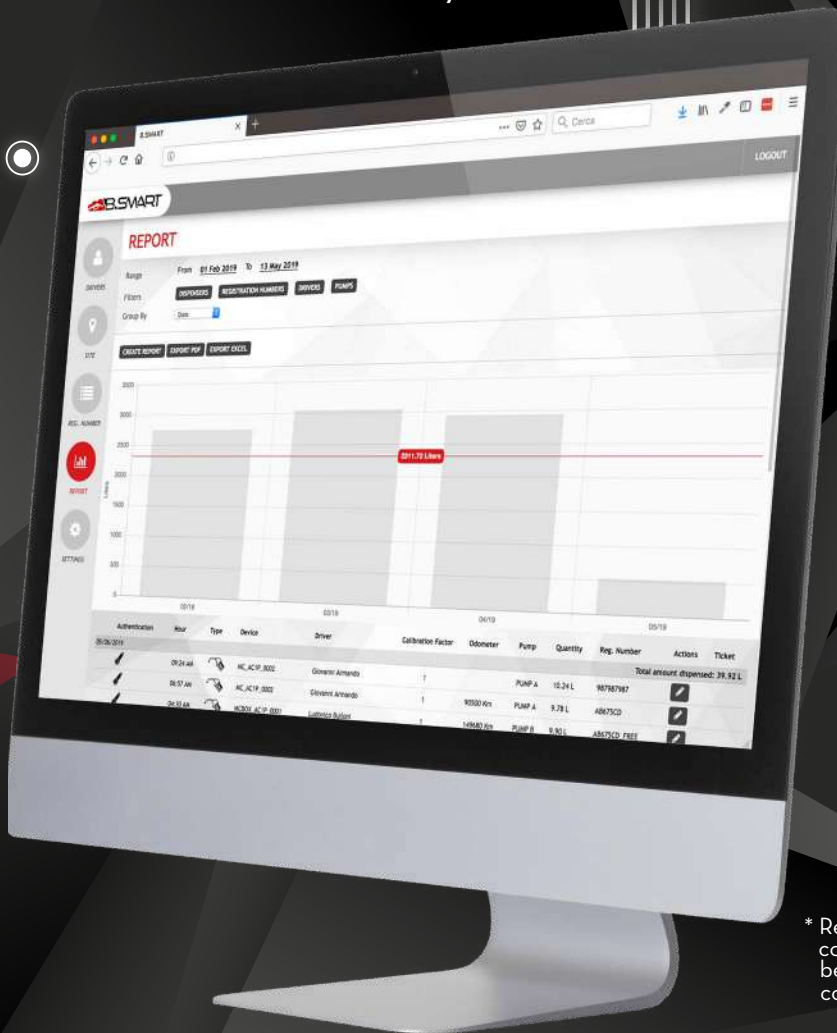

MANAGER
Web APP
B.SMART

UPDATE

Update information and data in real time*.

CONTROL

Control and collect all the information in every condition*.

NO FEE

Unlike most competitors, PIUSI B.SMART has a remote access app-based with:

No rental or recurring fee!

Receive a receipt of the transaction once completed*.

RECEIVE

* Real time as long as B.Smart Smart phone APP is connected to the internet. Otherwise, data will be transferred once B.Smart Smart phone APP connects to the internet. (Wi-Fi or mobile network).

HARDWARE DEVICES FOR PIUSI B.SMART

piusi.com



MCBOX B.SMART

*MCBOX B.SMART control panel
to be used with the existing fueling
equipment.*



IT CAN CONTROL:

- PUMP (UP TO 2 PUMPS)
- PULSE METER
- NOZZLE CONTACT

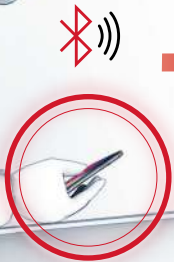

PIUSI B.SMART runs exclusively with the **dedicated MCBOX B.SMART control unit:**

- **Top performance and reliability**, all from one supplier
- **Real time communication** between the dispenser and the PC
- **Made in Italy**; quality guaranteed by PIUSI

Enter the era of the SMART Fuel Management System **simply upgrading your MC hardware with the NEW dedicated KIT UPGRADE** and change the way you manage your fleet.

2 hose FMS

SUITABLE FOR
HIGH FLOW RATE

Key pad
in case of no smart
device availability

AC version

HEAVY DUTY

NO RECURRING FEES

B.SMART ADDITIONAL FEATURES

TANK WATCHDOG ADD-ON

B.SMART Tank Watchdog is the perfect add-on for a **complete and updated tank level control**. It allows you to:



➔ 1 TANK WATCHDOG TANK LEVELS

Adding the level indicator OCIO, the system allows you to monitor the fluid level in **your tanks in real time** and **gives alarms in case of malfunction** or low levels. A perfect add-on for a complete and updated tank level control. You can connect also any 420 mA or 0-10 V fluid gauge or run the system without any gauge **thanks to the "virtual tank" option**:

- **Set level alarms** and get notifications on the tank level
- **Possibility to configure** high level or low level alarms
- **Stop the pump** according to the level of the fluid
- **Send an automatic e-mail to notify** when you reach the level alarm set

B.SMART ADDITIONAL FEATURES

TANK WATCHDOG ADD-ON



- **Monitor** the tank level (add fluid fills, usage and adjustments);
- **Set level alarms;**
- **Manage suppliers;**
- **Follow** inventory price values and trends;
- **Access and download** reports from anywhere.

2

TANK WATCHDOG

FLUID PRICE & VALUE

You can always have at your fingertips the fluid level value & fluid volume: you can **define the refuelling price** and **verify the current tank level value**:

- **Manage suppliers of the fluids** to keep track of the date, price and quantity bought
- **Get real time data** of the value of your fuel inventory
- **Follow** fluid price trends
- **Access and download reports** from any internet connected device thanks to the cloud software

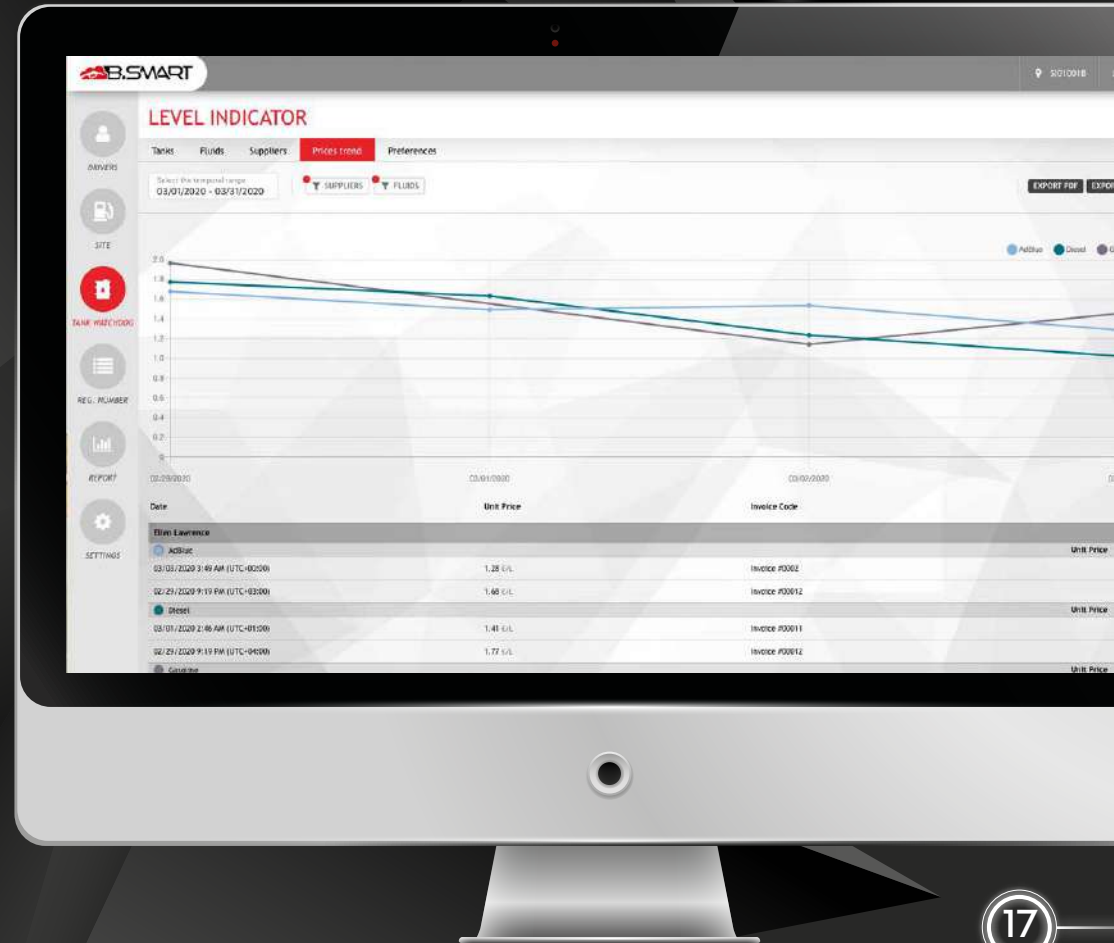

B.SMART ADDITIONAL FEATURES

FUEL ECONOMY ADD-ON

Enhance your system and become even more **smart** with the **FUEL ECONOMY ADD-ON** for B.SMART! Thanks to this new module, you can now **completely manage and increase the profitability of your fleet:**

- **Integrated** fleet management
- **Manage consumption**, cross-checking vehicles and drivers
- **Manage drivers' and vehicles' limits**
- **Add, check and manage** the on-road refueling transactions

IMPLEMENT

Implement savings and optimization strategies.

PROFITABILITY

Limit fuel usage per vehicle/driver and/or time thus **increasing the profitability of your fleet.**

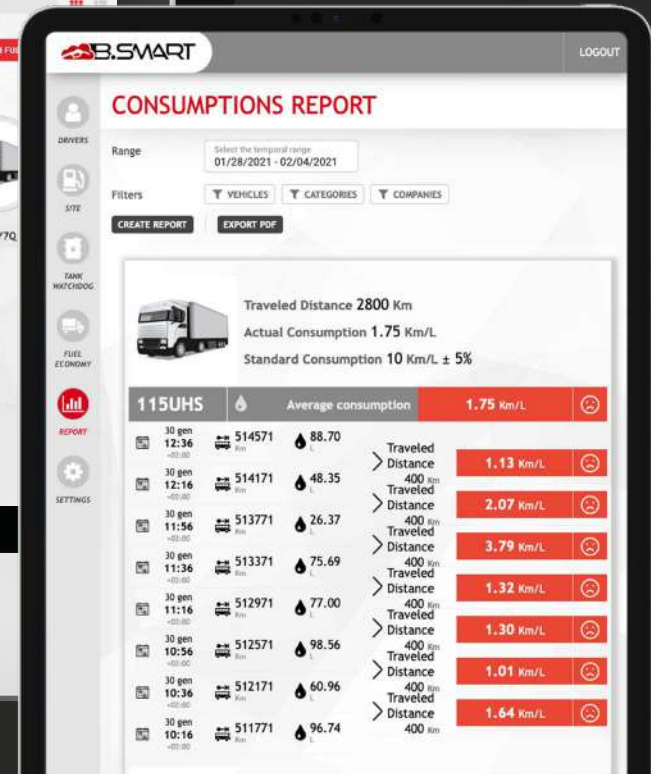
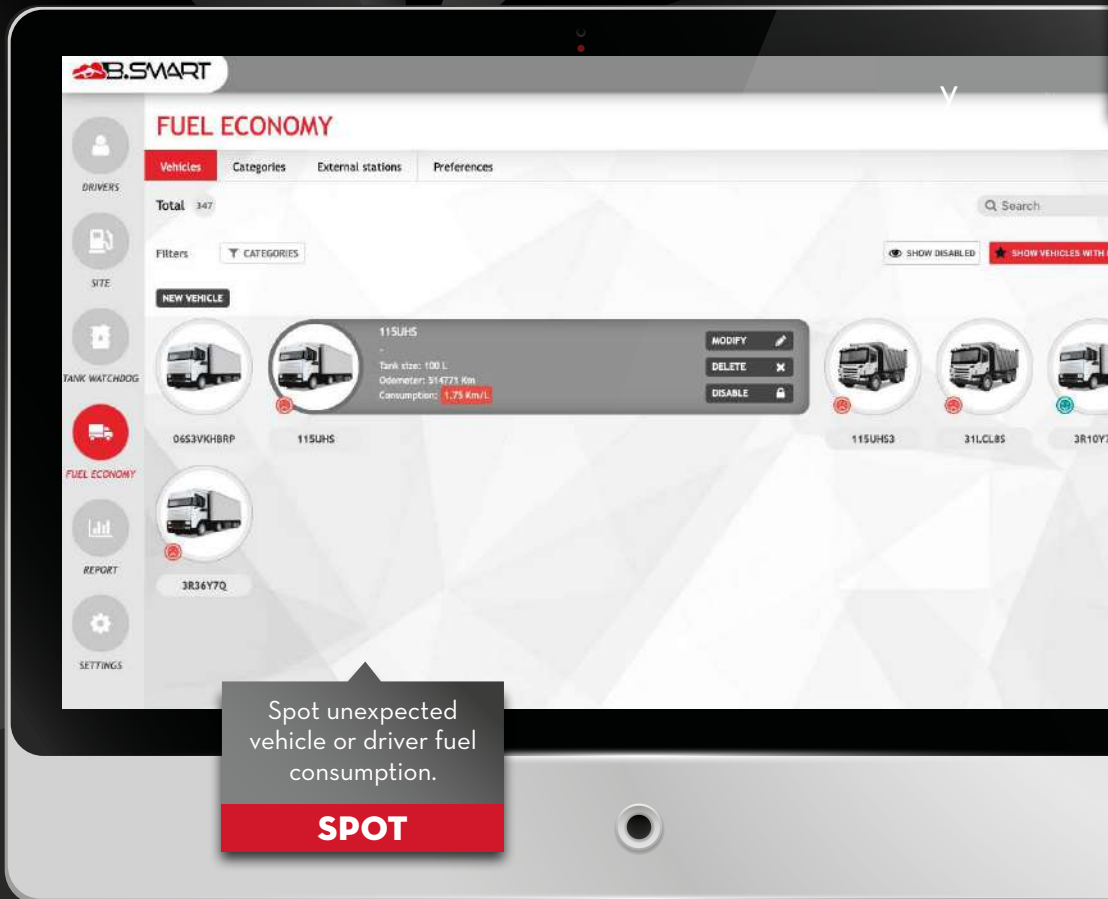

B.SMART ADDITIONAL FEATURES

FUEL ECONOMY ADD-ON



1

FUEL ECONOMY

FLEET MANAGEMENT

Thanks to this new add-on, you can:

- Add all the vehicles of your fleet to the **B.SMART WEB APP** system.
- Group all the vehicles according to a **specific and personalized setting**
- Add the images of your vehicles and drivers to the WEB APP for **quick and easy identification**
- Spot drivers' **high fuel consumption**
- Set **driver and vehicle limits** based on quantities or time frames

QR CODE IDENTIFICATION

The QR code allows you to **identify immediately the vehicle with 100% certainty**: it saves time during the refuelling process and reduces the risk of human error.

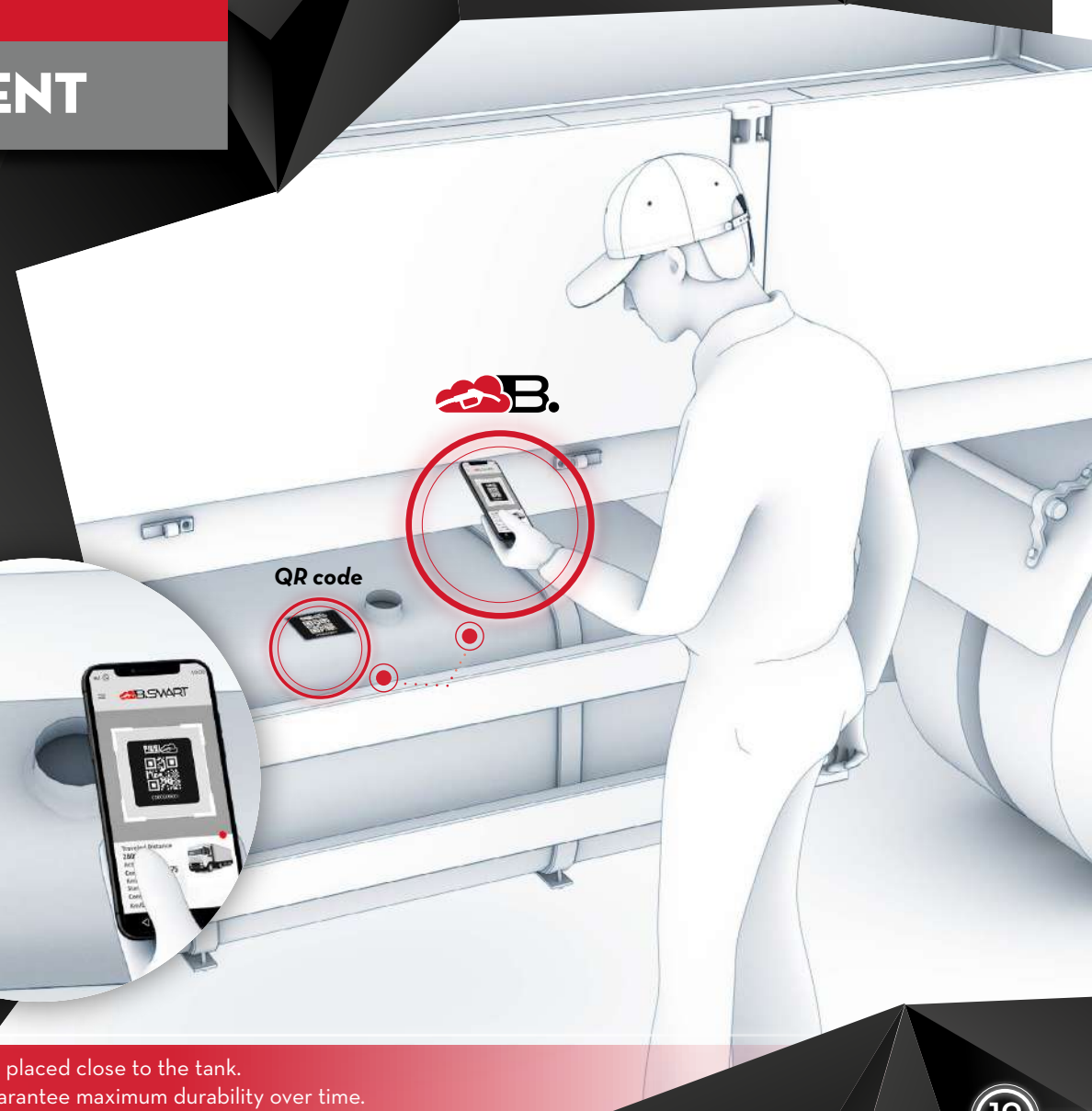

The QR label is sized to **PERFECTLY FIT ALL VEHICLES** and can be placed close to the tank. The extra-resistant adhesive glue and laser scratchproof engraving guarantee maximum durability over time.

B.SMART ADDITIONAL FEATURES

FUEL ECONOMY ADD-ON



FUEL ECONOMY CONSUMPTION REPORT

Thanks to this new add-on, you can have detailed reports of:

- Fuel/DEF dispense transactions
- Vehicle consumption, spotting deviations vs standard
- Drivers' usage per vehicle, tracking the driving behavior of the operator
- Spot drivers' high fuel consumption
- Add additional transactions from service station and other sites, highlighting offsite fuel/DEF costs in order to have a complete overview on the driver and vehicle trends/activities.





PIUSI B.SMART



PRODUCT RANGE



PART NUMBER	DESCRIPTION	FLUIDS	FEATURES		
			AC V/Hz	Power Watt	Amp. Max.
 ↘ F00599500	MCBOX B.SMART • 2P cETL KEYPAD 50 ACCESS	Any	100V-240V 50/60Hz	5W	15 A



ACCESSORIES

PART NUMBER	DESCRIPTION
 ↘ F00770D00	DRIVER ACCESS (x5)
↘ F00770D10	DRIVER ACCESS (x15)
↘ F00770D20	DRIVER ACCESS (x50)
 ↘ F1590400A	USER KEY (Yellow key: 10 pcs) Emergency only

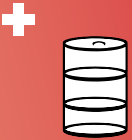

PART NUMBER	DESCRIPTION
 ↘ F1270800C	PEDESTAL (Cube • MCBOX)
 ↘ R12737000	KIT WALL SUPPORT (Cube • MCBOX)

ADD-ON

TANK WATCHDOG ADD-ON

PART NUMBER	DESCRIPTION
	↘ F00770L20 B.SMART TANK WATCHDOG ADD-ON • ONE TIME FEE
	↘ F00755250 LEVEL INDICATOR OCIO 2.0 • RS-485 120V - 50/60HZ

FUEL ECONOMY ADD-ON

PART NUMBER	DESCRIPTION
	↘ F00770F20 B.SMART FUEL ECONOMY ADD-ON • ONE TIME FEE
	F17299Q00 B.SMART FUEL ECONOMY • 45 QR CODES



PIUSI B.SMART: ALWAYS A STEP AHEAD!

PIUSI B.SMART is available worldwide through a professional network of distributors.

Get in touch with our local partner to order your B.SMART product or contact PIUSI for further information.



The logo features the word "PIUSI" in a bold, white, sans-serif font. Below the text is a thick white horizontal bar. To the right of the bar is a registered trademark symbol (®). The background is a dark, abstract geometric pattern of triangles and lines, with some lines ending in small white dots.

PIUSI
®

MADE IN ITALY

piusi.com/usa

PIUSI USA, Inc. • 3901 Anglers Ave Fort Lauderdale, FL 33312
tel. 954 584 1552 • fax 954 584 1554 • sales.usa@piusi.com

04.22 • EN

The Company reserves the right to modify the information contained in this catalogue without any prior notice. Copyright PIUSI S.p.A. ©



FUEL MANAGEMENT SYSTEMS



DISPENSERS



KITS



PUMPS



METERS



NOZZLES

SELF SERVICE B.SMART

FEATURES

- FUEL MANAGEMENT SYSTEM B.SMART INTEGRATED
- NO SOFTWARE INSTALLATION REQUIRED
- SUITABLE FOR FLEETS OF ALL SIZES
- REAL TIME FEEDBACK FROM ANYWHERE
- BUILT-IN FILTER
- ALL-IN-ONE EQUIPMENT
- COMPACT DESIGN

Top quality diesel dispenser by PIUSI, combined with the innovative B.SMART fuel management system: this is the core of the new SELF SERVICE B.SMART. A complete device specifically engineered to fit all diesel transfer needs while performing all the features of a fuel management software in terms of monitoring, controlling and managing the consumption of fuel by the fleet.

This dispenser performs: a sturdy design to ensure proper function in any working condition, a vane pump with incorporated bypass for a high flow rate (up to 90 l/min) and an oval gear meter to ensure maximum precision in measurement. An automatic nozzle with swivel connection, ergonomic and easy to handle, and a water absorption filter completes its components.

PERFORMANCE

UP TO 30 GPM	AC VOLTAGE
FLOW RATE	POWER
± 0,5%	BLUETOOTH
ACCURACY	CONNECTION



SELF SERVICE B.SMART



CODE	WEIGHT		PACKAGING			N. BOXES / EUROPALLET	
	KG	LBS	MM	INCH	PCS/BOX		
F00748500	61	133	1480X490X400	58,3X19,3X15,7	1	-	-



FILTRATION



TANK MONITORING



HOSE REEL



ACCESSORIES



MERCHANDISE



AIR



ANTIFREEZE



AdBlue®



BIODIESEL



DIESEL



FOOD



GASOLINE



GREASE



KEROSENE



OIL



WATER



WINDSCREEN

CHART

IN THE BOX

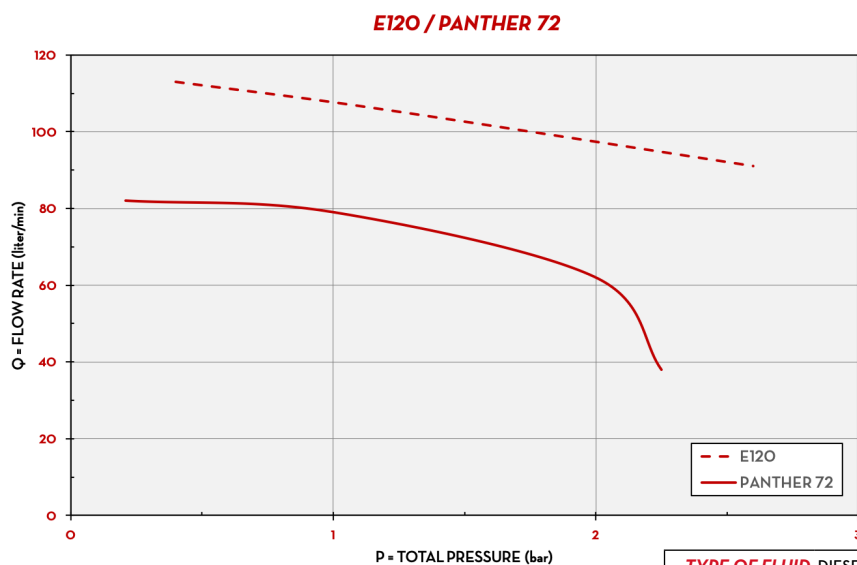

- SELF SERVICE B.SMART DISPENSER
- DELIVERY HOSE
- AUTOMATIC NOZZLE
- DRIVER ACCESS ADD-ON
- INSTRUCTION MANUAL

DETAILS



TYPE OF FLUID DIESEL
TEMPERATURE 20°C

DIMENSIONS

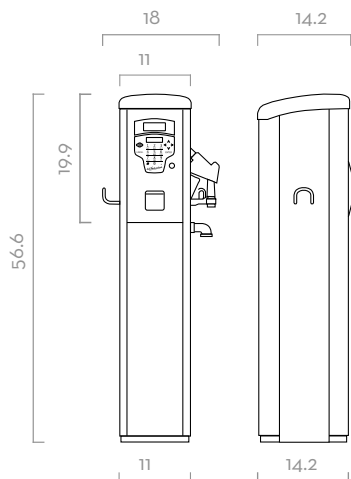

Dimensions expressed in inches

MATERIALS

TECHNICAL DATA

CODE	DESCRIPTION	FLUIDS TYPE	FLOW RATE		VOLTAGE			PUMP	METER	NOZZLE	FILTER	INLET	HOSE		
			L/MIN	GPM	AC V/HZ	DC VOLT	POWER WATT						AMP. MAX.	LENGTH	Ø
F00748500	SELF SERVICE 100 120v B.SMART 50 DRIVERS	D	120	30	120 V	60 HZ	550 W	3,3 A	E120	K600/3	A120	30·M	1 1/2"	4M	25MM

SELF SERVICE B.SMART

B.SMART DISPENSERS