



DISPENSERS



FUEL KITS



PUMPS



METERS



NOZZLE



FILTRATION

SELF SERVICE FM 2.0

FEATURES

- IDEAL FOR FUEL MANAGEMENT
- TANK LEVEL INDICATOR
- TICKET PRINTER
- MULTI-USER MANAGEMENT
- STURDY STRUCTURE
- EASY MAINTENANCE
- HIGH DISPLACEMENT VANE PUMP
- SSM 2.0 SOFTWARE REQUIRED
- IP55 PROTECTION RATING

The PIUSI SELF SERVICE FM 2.0 is the top-level, all-in-one dispenser for diesel with integrated LAN connection to guarantee continuous communication between dispenser and PC, water captor filter to ensure the highest purity of fluids, OCIO 2.0 tank level indicator and an electronic panel able to manage up to 1000 users and 650 transactions. Compatible with SSM 2.0 software.

PERFORMANCE

UP TO

30 GPM

FLOW RATE

AC

CONTINUOUS DUTY

POWER

± 0.5%

ACCURACY

UP TO

1000

USERS



INTEGRATED TICKET PRINTER



SELF SERVICE FM 2.0

PACKAGING

PART #	WEIGHT		PACKAGING			N. BOXES / EUROPALLET	
	KG	LBS	MM	INCH	PCS/BOX	✈	🚚
FO0743050	57	126	1080X488X400	43X19X16	1	6*	4



FLUID
MONITORING

CHART

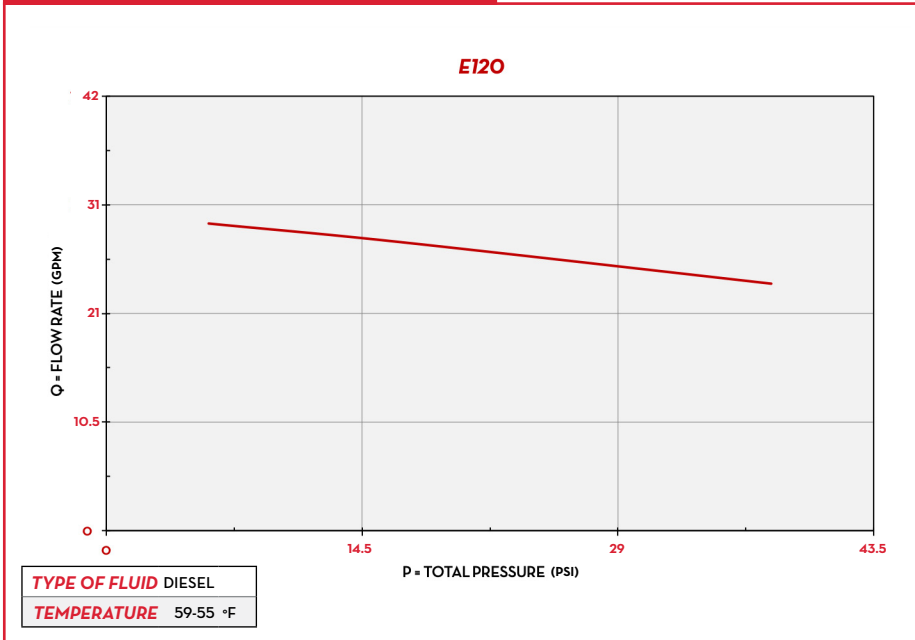

IN THE BOX

- SELF SERVICE FM 2.0 UNIT
- DELIVERY HOSE
- AUTOMATIC NOZZLE
- INSTRUCTION MANUAL

DETAILS



DIMENSIONS

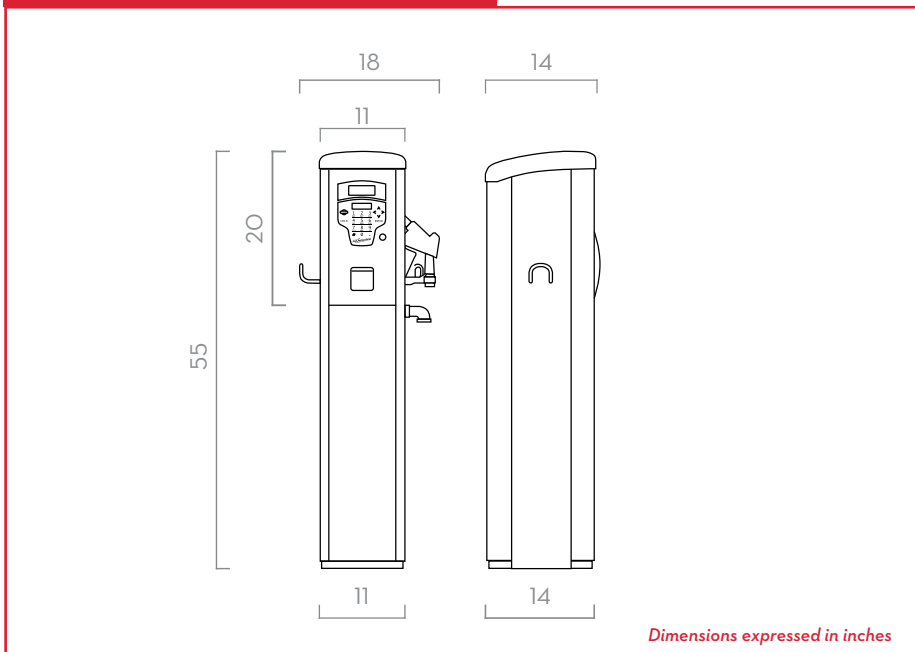

CONTENTS

- **PUMPS:**
E120
- **METER:**
K600/3
- **NOZZLE:**
A120 AUTOMATIC NOZZLE
- **FILTER:**
WATER CAPTOR

TECHNICAL DATA

PART #	DESCRIPTION	FLUIDS TYPE	FLOW RATE		VOLTAGE			PUMP	METER	NOZZLE	FILTER		INLET	PC
			L/MIN	GPM	AC V/HZ	DC VOLT	POWER WATT				AMP. MAX.	H2O FILTER		
FO0743050	SELF SERVICE FM 2.0 - 120V/60HZ 26GPM	D	113	30	120/60	1000	10	E120	K600	AUTO	YES	30µ	1" 1/2	YES

SELF SERVICE FM 2.0

SELF SERVICE